

9300 Series High-Voltage Battery Emulator



Emulation of Batteries and Energy Storage Systems for Testing Powertrains, Fast Chargers, Distributed Energy Resources (DER), and more.

Key Features

- Dual voltage range design: 600V, 1200V
- Modular & scalable power up to 2.4MW
 - 100kW per cabinet (parallel up to 24 cabinets)
 - Current 333A per cabinet (up to 8,000A)
- Fast transient speeds: Slew Rate < 2mS
- 100% SiC-based technology
- Built-in Programmable Series Resistance with low capacitance for accurate emulation of real-world conditions
- Internal hardware design and software.
- Modes: Battery Emulation, Source and Load
- High insulation resistance to ensure product safety
- Regenerative power > 95% (Typical)
- Air-cooled (no liquid cooling) provides simplified maintenance
- Advanced digital measurements with charting
- Multiple control options: touch panel, LabVIEW®, IVI Drivers, & SCPI
- Flexible and easy HW and SW integration
- Easy to use remote touch panel; set it and forget it

Applications

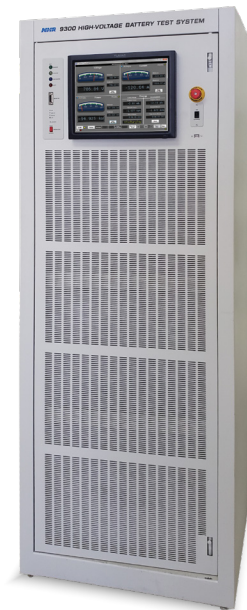
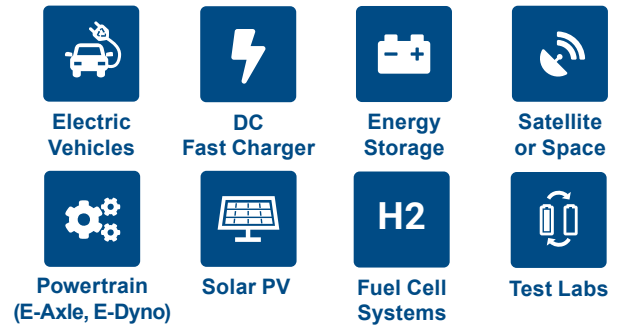

Model 9300 100kW Test System

The Industry's Most Accurate Battery Emulator for Simulating DC Power

The 9300 High Voltage Battery Emulator is the industry's leading test solution for automotive, aerospace, energy, and industrial markets. The 9300 is used by well-recognized OEMs, Tier 1, 2, and 3 manufacturers and suppliers, universities, government, and test labs, worldwide. Our flexible 9300 platform allows you to evolve with your test requirements from R&D and validation to production and end-of life.

The 9300 provides modular and scalable power from 100kW up to 2.4MW. Its dual voltage range of 600V and 1,200V covers both lower and higher power applications within a single product. Unlike custom built solutions, the 9300 provides maximum flexibility in voltage and power, providing full power from 300V – 1,200V + with operation down to 30 V.

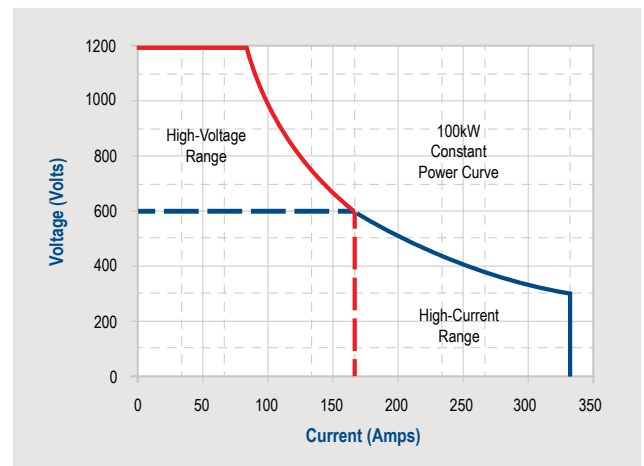

Figure 1 - Wide Constant Power Operating Envelope

Modular and Scalable Power Provides Future-Proofing

NHR's Battery Emulators are designed for fully independent operation. Additional 100kW cabinets can be run synchronously in parallel up to 2.4MW/8000A, increasing the maximum power and current capability to the level required. This modular expansion allows you to scale power as needed (*Fig. 2*).



Figure 2 - Modular and Scalable Power up to 2.4MW

Programmable Series Resistance

To model any battery and adapt to test needs, the voltage and the resistance values and behaviors of the equivalent battery model need to be programmable. For example, aside from setting the desired voltage, the ability to slew it at slow rates can emulate the change in voltage expected as a battery charges or discharges. *Figure 3* shows this effect of programmable series resistance as it is subjected to multiple discharge pulses. Since the change in voltage is proportional to the current with a programmable series resistance model, engineers can test a device as if it were connected to a new (low resistance) or an old (higher resistance) battery. This approach allows for faster, consistent, and safe testing.

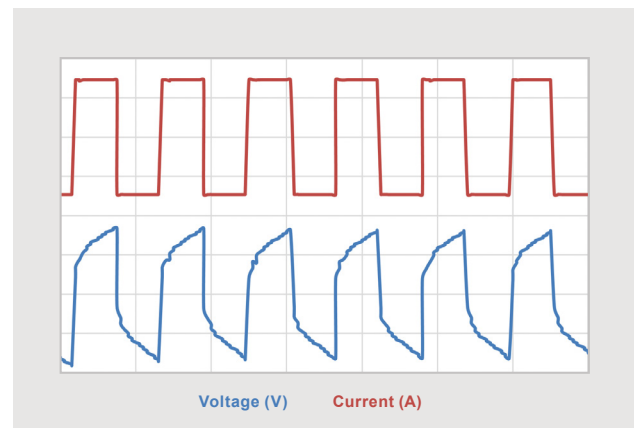
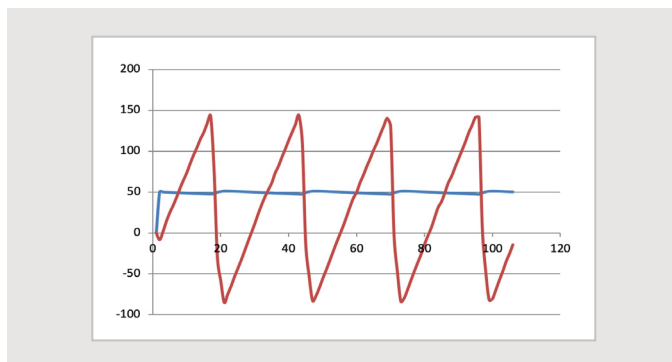

Figure 3 - EV Battery Simulation Using Series Resistance Model

Low Capacitance Provides Accurate Emulation

The low output capacitance of the 9300 provides accurate simulation of series resistance effects by allowing the output voltage to adjust proportionally to changes in current. By comparison, many regenerative power supplies have high output capacitance to reduce noise output. This high output capacitance disrupts the series resistance models and negates the functionality of a programmable series resistance. As a result, high output capacitance can lead to inaccurate battery simulation.

Testing with a Real Battery



Testing with a Battery Emulator

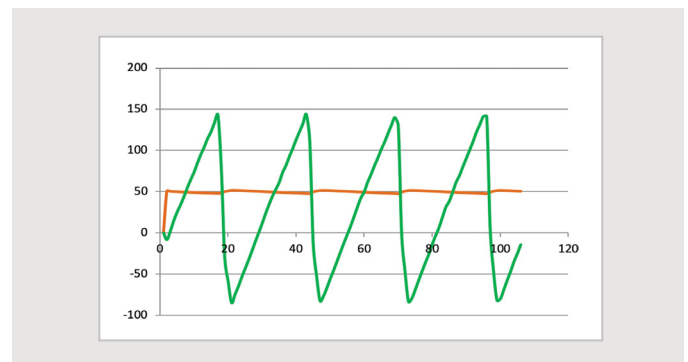

Figure 4 - Customer results show a 70% reduction in total test time by replacing real batteries using battery emulation.

Electric Powertrain Test Set-up Example For All Types of Powertrain Testing

Next generation battery emulation and DC Bus emulation provides a bi-directional approach for testing the electric powertrain. The 9300 sinks and sources power to maintain voltage regulation, accepts back EMF which prevents safety hazards, and has isolated input and output paths to eliminate single points of failure. The 9300 is easy to use and does not require additional fixturing and add-ons. Our approach provides high performance testing for a wide range of powertrain test approaches, as seen in **Figure 5**.

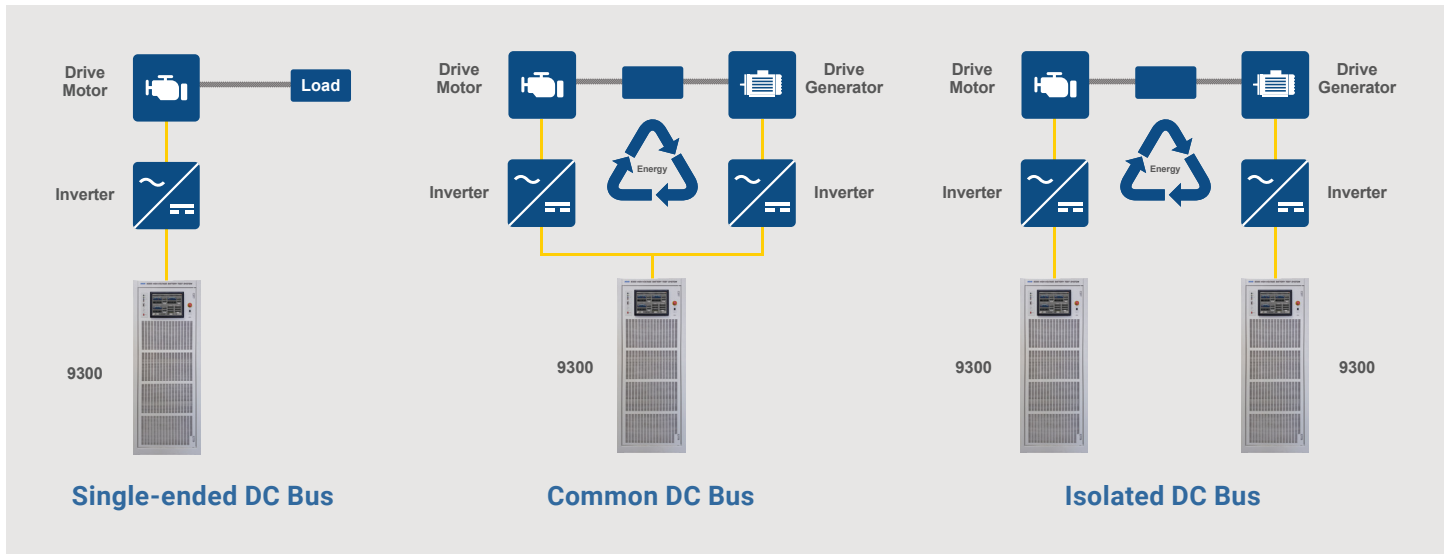
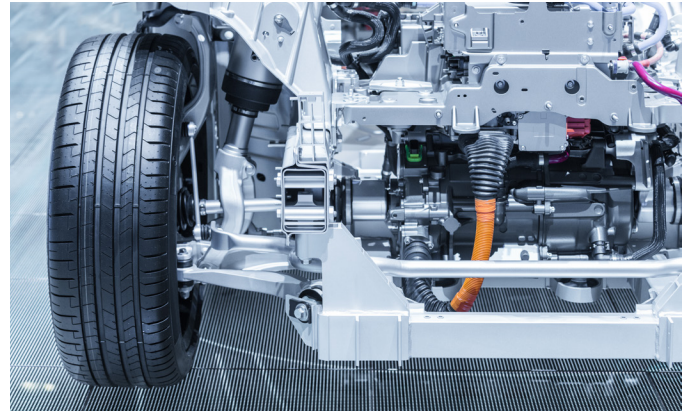

Figure 5 - Common Powertrain Test Set-Ups

Emulation for DC Fast Charger Test Set-up Example

The 9300 Battery Emulator supports traditional external software control, but also has a key advantage with its internal hardware design which is a faster and more accurate approach for emulating real-world conditions.

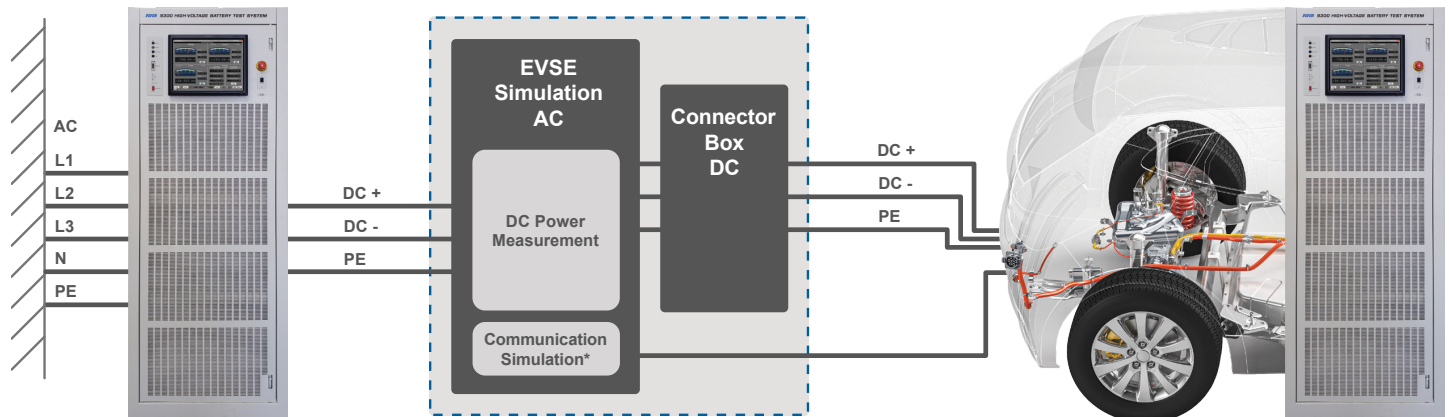

Figure 6 - Level 4 – EV Fast Charger Test Set-up Example

Model 9300 High-Voltage Battery Emulator

MODEL NUMBER*	9300-100	9300-200	9300-300	9300-400	9300-500	9300-600	9300-700	9300-800	9300-900	9300-1000	9300-1100	9300-1200
Rating	100kW	200kW	300kW	400kW	500kW	600kW	700kW	800kW	900kW	1000kW	1100kW	1200kW
Max Current @ 600V	333A	666A	999A	1332A	1665A	1998A	2331A	2664A	2997A	3330A	3663A	3996A
Current @ 1200V	±167A	±334A	±501A	±668A	±835A	±1002A	±1169A	±1336A	±1503A	±1670A	±1837A	±2001A
Programming Capability												
Operating States	Charge (Source), Discharge (Load), Standby, Battery Emulation											
Set Point Limits	Constant-Voltage (CV), Current (CC), Power (CP), Series Resistance (CR)											
Trip Point Limits	Min/Max Voltage, Current (per direction), and Power (per direction) with time delay values											
Charging Envelope	0 - 600V/±333A, 0 -1200V/±167A											
Discharging Envelope	30 - 600V/±333A, 60 - 1200V/±167A											
Voltage Accuracy	0.025% Set + 0.025% Range											
Current Accuracy	0.1% Set + 0.1% Range											
Slew Rate	Same polarity 10 - 90% < 2mS Low Range, < 3mS High Range											
Current Change Time	< 5mS											
Current Reverse Time	< 10mS											
Parallelability	Synchronous control for up to 24 channels (2.4MW)											
Macro Test Profiles												
Development Source	Touch-Panel, Import from Excel or User's System Controller											
Max. Steps	1000											
Min.Time Delay	50µS											
Max. Step Delay	1mS - 7 days											
Test Meas. (4-wire)	Range				Accuracy				Resolution			
Voltage, DC Avg.	0 - 600V/0 - 1200V				0.025% Reading + 0.025% Range				0.005% Range			
Current, DC Avg. Amp Hr	0 - 333A/0 - 167A				0.1% Reading + 0.1% Range				0.005% Range			
Power, Watt Hr	I Range x V Range				0.12% Reading + 0.12% Range				0.005% Range			
Time	1mS - 1 Yr				0.1% Reading				0.005% Range			
Temperature	0 - 150 °C											
Control												
Local User Interface	Touch-Panel with graphic meters & controls plus Macro screens											
Ext. Sys. Communication	LAN (Ethernet)											
Drivers	LabVIEW, IVI-COM, IVI-C											
Analog Current Monitor	0 to +10V charge/0 to -10V discharge											
Analog Voltage Monitor	0 to +10V full scale voltage											
External Inputs	Interlock input & power-off (eOff) input											
Software Watchdog	Programmable											
Physical (Single 100kW Cabinet)												
Connectors	Main power through buss bars											
Cabinet Dim. (HxWxD)	78 x 28 x 39"/1981 x 711 x 991mm											
Cabinet Weight	1200lbs/544kg											
Operating Temperature	0 - 35°C full power											
Input Power	3ø, 50 - 60Hz, 380VAC/200A or 480VAC/160A. Output Power reduced to 90kW below 360VAC input											
Input Power Factor	PF >0.997											
Isolation AC Input	800VDC Mains to Chassis & UUT - / 1500VDC Mains to UUT +											
Isolation UUT Input	800VDC UUT - to Chassis / 1500VDC UUT + to Chassis											
Internal Monitoring	Over-Voltage, Over-Current, Over-Power, Over-Temperature											

* Higher power models are available up to 9300-2400 at 2.4MW.

