

# TSURUGA

## MODEL **8505** Withstand Voltage & Insulation Tester

### Instruction Manual



---

---

## FOR SAFE USE

---

---

For safe use of this tester, please observe the following warning and caution.

---



### Regarding safety symbols

In order to help the users to use the testers safely, the following symbols are used in this manual.

---

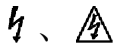

Place where there is a dangerous high voltage.



### Warning

It shows the content that a dangerous situation is possible which may cause a fatal accident or severe injury in case the tester is mishandled.



### Caution

It shows the content that a dangerous situation is possible which may cause a minor injury to user or only material damage in case the tester is mishandled.

---



### Warning

● **This tester is designed to output a high voltage. As there is a danger of an electric shock, please follow the directions below:**

- Do not touch output terminal, high voltage cables or test samples during the test.  
The places marked with  on the tester are the dangerous parts where the high voltage is generated.
  - Make sure to connect the protective ground terminal to the earth.
  - Do not short-circuit the output to the ground or commercial power supply line. It is dangerous as the housing of the tester is charged with high voltage. It also causes the breakdown of the tester.
  - When operating the tester, put on the rubber gloves of an electric operation purpose.
  - For the connection to the test specimen, use the enclosed high-voltage cable or an electric cable that confirms to the operating voltage.
- 

### ● Place for installation

- Never use or install this tester in the place where explosive or flammable materials as mentioned below are used or stored. (Occupational Safety and Health Act, Enforcement Regulations Appendix Table 1 Hazardous Materials )  
[Explosive materials], [Ignitable materials], [Inflammable materials], [Flammable gas], [Oxidizing materials]  
※ This tester uses metal internally. There is a risk of deterioration due to the occurrence of corrosion or rust and explosion or ignition by an electric spark.
  - Do not place objects on top of this tester or use it as a footstool.  
※ It affects the heat dissipation causing internal temperature rise and break-down.  
※ There is a risk that the upper part is deformed.
- 

### ● Storage

- Take care that the water drops like from rain do not wet the tester.  
※ There is a risk of electric shock or malfunction.
  - Do not place the tester sideways. Take care during handling and do not let it fall down due to the vibration etc.  
※ There is a risk of damage of internal mechanism or malfunction.
-

---

**⚠ Caution****● Do not use the tester in the following places**

Followings can cause the trouble due to break-down or malfunction.

- ▶ Rain, water drops or direct sunlight places.
  - ▶ Places having high temperature, high humidity, dust and corrosive gas.
  - ▶ Places having external noise, radio waves or static electricity.
  - ▶ Places which are unstable or having lot of mechanical vibrations or shock.
  - ▶ Places where high sensitivity measuring testers or receivers are located nearby.
- Do not open the case or modify the tester as it may cause a danger of an electric shock or other troubles.
  - If the operation is abnormal, turn off the power supply switch immediately and unplug the power cord.
  - Make sure to stop the use and turn off the power supply during the maintenance or checking.
  - Do not use the tester where the ventilation is poor.

Cooling system of this tester is forced air cooling from the rear panel. Mainly it takes in the air from the bottom and discharge to the rear side. As heat may be trapped and become the reason for the fire, always keep space of more than 10cms between the top, side, rear and the walls. In between the bottom surface and the floor (the height of rubber foot is about 14mm), do not place any object like paper, plastic etc. which can be easily sucked in.

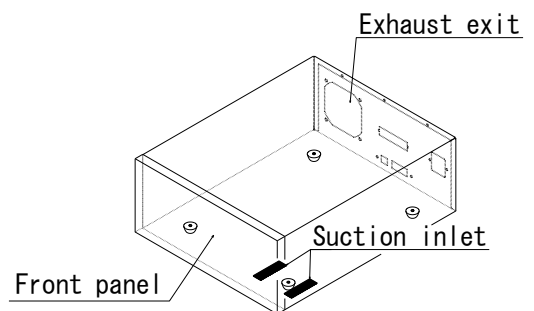

---

**● Apply the voltage to capacitance load (test sample)**

The output voltage may rise higher than the case of no load depending upon the capacitance value of the load. Also, in case of voltage dependent load (test sample), the waveform distortion may occur. In case of test voltage 2kV, the influence of capacitance less than 2000pF can be ignored.

---

**● Transportation**

- Hold the chassis (bottom plate) during transportation.
- Do not carry the tester holding its red bushing of high voltage terminal section (refer to ⑩ of "1. Part names and functions").
  - ※ The bushing (red) may get damaged and there is a risk of serious injury when this product falls down.
- Minimize the mechanical vibration or shock when transporting the tester.
  - ※ There is a risk of damage of internal mechanism or malfunction.

---

**● Regarding Interlock**

This tester is provided with interlock function.

No test can be made when interlock function is in operation.

The interlock function can be released by plugging the enclosed remote /out plug into the remote I/O connector ⑤ and pressing the stop switch ⑫.

---

---

---

# Content

---

---

<b>Preface</b> .....	<b>1</b>
Functions.....	1
<b>Confirmation prior to use</b> .....	<b>2</b>
Inspection at the time of unpacking .....	2
Cautions for handling.....	2
<b>1. Names and functions of each part</b> .....	<b>3</b>
Front Panel .....	4
Rear Panel.....	7
<b>2. Preparation before use</b> .....	<b>9</b>
Connection of power cord.....	10
Connection of the protective earth terminal .....	10
Method of removing and mounting of key cover (option) .....	10
Connection to the external control equipment.....	11
Connection of the high-voltage cable.....	11
Power on and off.....	12
<b>3. Panel operation</b> .....	<b>13</b>
Expression of the panel display of setting operation .....	14
Key Lock .....	14
Configuration of the display.....	15
Setting of test conditions.....	15
READY state .....	16
Display during the test .....	17
Display example of judgment result.....	17
<b>4. Setting of a single test and an automatic test (ACW→IR, IR→ACW)</b> .....	<b>19</b>
Types of test .....	20
Selection of test mode .....	21
<b>5. Setting of withstand voltage test conditions</b> .....	<b>23</b>
Setting of test voltage.....	24
Upper limit judgment value .....	25
Lower limit judgment value .....	26
Setting of the voltage rise time (rise time) .....	27
Setting of the voltage fall time (fall time) .....	28
Setting of the test time .....	29
Setting of test voltage frequency.....	30
<b>6. Setting of insulation resistance test (IR) conditions</b> .....	<b>31</b>
Setting of test voltage.....	32
Setting of resistance range .....	33
Upper limit judgment and lower limit judgment value .....	34
Setting of mask time .....	35
Setting of test time .....	36
<b>7. Memory operation</b> .....	<b>37</b>
Overview.....	38
Call and setting of memory .....	39

<b>8. Program operation.....</b>	<b>41</b>
Overview.....	42
Flow of program operation.....	43
Call of program operation.....	44
Setting of the program.....	45
<b>9. Test method (From the start of the test till the judgment) .....</b>	<b>47</b>
Method operation of single withstand voltage test.....	48
Operation method of single insulation resistance test.....	49
Operation method of automatic test.....	50
Operation method of program operation test.....	51
<b>10. Other functions.....</b>	<b>53</b>
Double action start.....	54
GOOD hold.....	54
Momentary start.....	54
FAIL mode.....	54
NG start.....	54
Setting method.....	55
Setting of the buzzer.....	56
Interlock.....	57
<b>11. Remote I/O.....</b>	<b>59</b>
Test contents depending on remote I/O.....	60
Connector pin array and pin function.....	61
Call Memory No. from remote I/O.....	62
Combination of Memory No. and MEM SET Signals.....	63
I/O control by MEM SET.....	64
I/O control by REAR MODE.....	65
I/O Control with combination of REAR MODE and MEM SET.....	67
I/O Control with separate judgment (During GOOD judgment).....	68
I/O Control with separate judgment (During ACW-NG Upper limit judgment).....	69
I/O Control with separate judgment (During IR-NG lower limit judgment).....	70
Timing Chart: Details from the start to the high voltage output.....	71
Interlock signal.....	72
Protective function operation (PROTECTION).....	72
Input signal.....	73
Output signal and the control power supply.....	74
<b>12. PC remote control.....</b>	<b>75</b>
RS-232C•USB Interface.....	76
<b>13. Error message.....</b>	<b>77</b>
Error display.....	78
Coping with error display.....	78
<b>14. Maintenance.....</b>	<b>79</b>
Cleaning.....	80
Problem solving.....	80
Calibration.....	80

<b>15. Specifications .....</b>	<b>81</b>
Withstand voltage test .....	82
Insulation resistance test .....	84
Memory operation.....	85
Program operation.....	85
Other functions .....	86
Input Output signal .....	86
RS-232C•USB Interface.....	87
General specification.....	88
Setting of the default value .....	88
Dimensions .....	90
MEMO.....	91

---

# Preface

---

For proper use of this tester, read these instructions carefully before initial operation. Make sure that this instruction manual is available to the responsible person for the operation. Besides, keep this manual near the tester so that the operator can read it any time.

## Functions

---

As this tester handles the high voltage, so it is designed with a lot of protective functions and a number of considerations for the safety of the users.

- The withstand voltage tester has the capability of maximum output of 5kV and output capacity of 100VA.
- Precise test can be made due to upper and lower limit leakage current setting.
- As the insulation tester, this model is provided with 6 ranges of DC25V~DC1000V.
- The displays of test voltage, current and test time are easy-to-read green large LED.
- 16 sets of memory are equipped which can write and read the test conditions.
- 16 sets of memory are equipped which can program 16 steps of applied voltage of withstand voltage test and test time.
- It is possible to control input of the start/stop of the test from the outside by remote I/O connector. Besides, matching with the status of this tester, the output signals like “waiting”, “under test” or “decision result” etc. are output in open collector.

---

---

# Confirmation prior to use

---

---

## Inspection at the time of unpacking

---

(1) When unpacking

When the tester is delivered, check whether it has been damaged in transit and unpack it carefully. In case the tester does not operate as per the specification due to damage, contact the dealer from where you have purchased or sales office.

(2) Checking of the contents

Check the packing box which contains the main item and the standard accessories as listed below.

List of accessories

Instruction manual (Main document)		1 set
RS-232C•USB Interface manual		1 set
High voltage cable	2m	1 pair
Earth wire	3m	1 piece
Power supply cord	2.5m	1 piece
Remote I/O plug		1 piece (36P)

---

 **Caution**

•For external communication RS-232C (D sub 9 pin model 5881-11-020)

When the customer procures it, it is requested to use the inch pitch screw type.

USB cable (Standard A-B model 5881-12-010) is optional.

---

## Cautions for handling

---

Since this tester deals with high voltage, it is designed paying special attention to the safety. However, it is still dangerous as it outputs high voltage of max. 5kV. An erroneous handling may cause fatal accident. In order to avoid any accident, strictly observe the following cautions and take utmost care for safety.

---

 **Warning**

If the earthing is insufficient, there is a risk of electric shock.

(1) Make sure to connect the protective ground terminals (rear panel) to the earth. If the grounding is insufficient and the output is short-circuited to the earth or power supply line, the tester housing is charged with high voltage and it is very dangerous when the operator touches the outer box.

Check if the earthing cable is disconnected or not.

(2) During the test, never touch the output terminals, high voltage cable and test samples.

(3) When making a connection to the test sample, with output OFF, connect the LOW side prior to other.

(4) When operating this tester, put on rubber gloves for electric shock prevention.

---



---

---

## 1. Names and functions of each part

---

---

Front Panel.....	4
Rear Panel.....	7



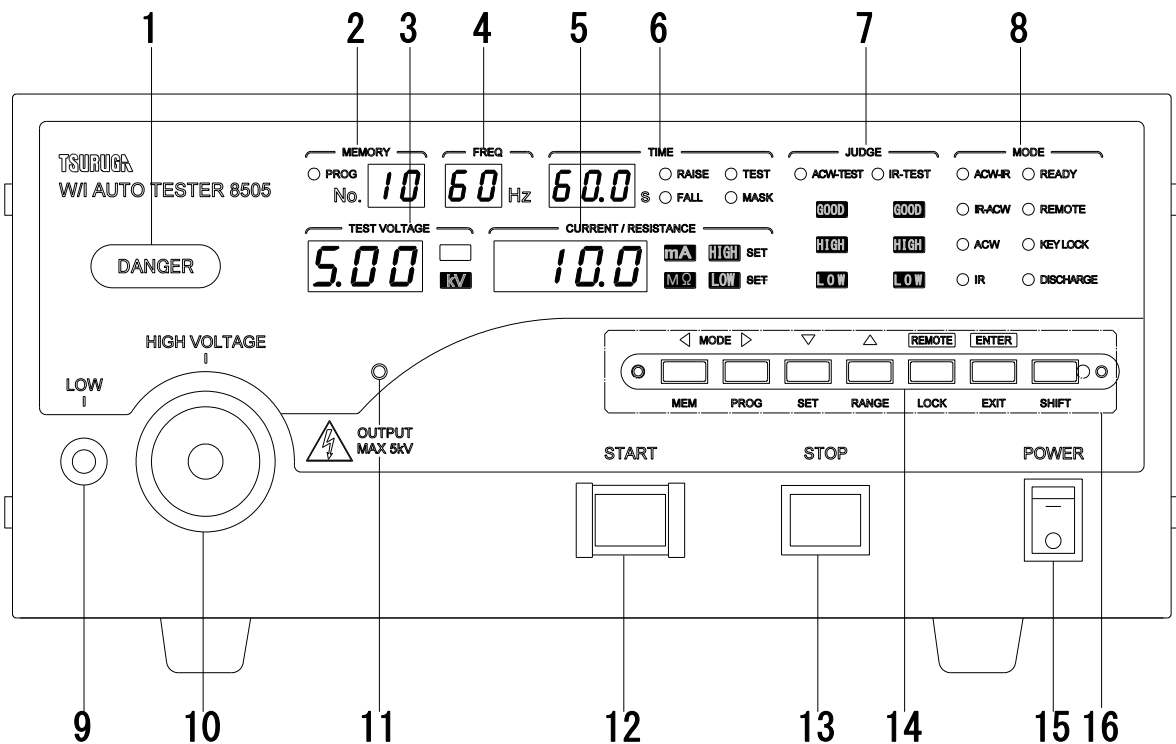

## Front Panel



No.	Name	Function description	
1	DANGER Lamp	Gives warning lamp when the test voltage is an output.	Lighting of each lamp, refer blinking state
2	MEMORY No.	Memory operation, display of memory number and step number of program operation Memory, Lit up during program operation , blinking during setting up	
	PROG Lamp	During program operation, Lit up during setting	Lighting of each lamp, refer blinking state
3	TEST VOLTAGE	Withstand voltage test : Display of setting of test voltage and value of output voltage. Program operation : Setting of step off (end) (withstand voltage test only) Insulation test : Setting of the test voltage	
	V, kV Lamp	Unit display of test voltage	Lighting of each lamp, refer blinking state
4	FREQ Display	Display of the frequency setting of the test voltage in regards to withstand voltage test	
5	CURRENT /RESISTANCE	Withstand voltage test : Display of leakage current measurement value and result value, blinking during setting up Insulation test : Display of insulation resistance measurement value and result value, blinking during setting up	
	HIGH SET Lamp	Lights up when upper limit value is set	Lighting of each lamp, refer blinking state
	LOW SET Lamp	Lights up when lower limit value is set	
6	TIME	Withstand voltage test : Display of RAISE, TEST, FALL time Insulation test : Display of MASK, TEST time	
	RAISE Lamp	During withstand voltage test RAISE operation, Lights up during setting	Lighting of each lamp, refer blinking state
	TEST Lamp	During withstand voltage test TEST operation, Lights up during setting	
	FALL Lamp	During withstand voltage test FALL operation, Lights up during setting	
	MASK Lamp	During MASK time of insulation test, Lights up during setting	

No.	Name	Function description	
7	JUDGE	Display of decision result and test status	
	ACW-TEST Lamp	Lights up during withstand voltage test	Lighting of each lamp, refer blinking state
	IR-TEST Lamp	Lights up during insulation test	
	GOOD Lamp	Lights up when the decision result of the test is passed	
	HIGH Lamp	Lights up when the decision result of the test is larger than the upper limit decision value	
	LOW Lamp	Lights up when the decision result of the test is less than the lower limit decision value	
8	MODE	Display of test mode and operation mode	
	ACW-IR Lamp	Withstand voltage test → Lights up in insulation test mode, <u>blinking during setting</u>	Lighting of each lamp, refer blinking state
	IR-ACW Lamp	Insulation test → Lights up in withstand voltage test mode, <u>blinking during setting</u>	
	ACW Lamp	Lights up during withstand voltage test mode , <u>blinking during setting</u>	
	IR Lamp	Lights up during insulation test mode, <u>blinking during setting</u>	
	READY Lamp	Lights up during READY status	
	REMOTE Lamp	Lights up during remote control status	
	KEYLOCK Lamp	Lights up during locked status of key operation setting	
	DISCHARGE Lamp	Blinking during the discharge of insulation test	

## 1. Names and functions of each part

No.	Name	Function description
9	LOW terminal	Low-voltage side terminal of the test voltage output, the tester case and the same potential
10	HIGH VOLTAGE terminal	High-voltage side terminal of the test voltage output, the output of the high voltage during the test
11	Buzzer	Buzzer
12	START switch	Start switch of the test
13	STOP switch	Interruption and judgment return switch of the test
14	Setup key	Key for reading and writing the setting of the test conditions such as test mode, test voltage, upper and lower limit values, test time etc.
	 MEM	Key to select each setting after entering the setup mode ----- Hold down the SHIFT and press the MEM key to switch to the memory operation
	 PROG	Key to select each setting after entering the setup mode ----- Hold down the SHIFT and press PROG key to switch to the program operation
	 SET	Key to change each setting item ----- Hold down the SHIFT and press SET key for some time to switch to other function setting
	 RANGE	Key to change each setting item ----- Hold down the SHIFT and press RANGE key while setting to switch to the decimal point
	REMOTE LOCK	Key to set/release remote operation ----- Hold down the SHIFT and press LOCK key to switch to Key lock set/release
	ENTER EXIT	Stores the set value and exits from the setting operation ----- Hold down the SHIFT and press EXIT key to interrupt the setting operation and READY state
	SHIFT	Used in combination with other keys Function that is displayed on the lower side of the key is enabled
15	POWER switch	Switch for the power
16	Key cover	Protect the set up key from being touched (option)

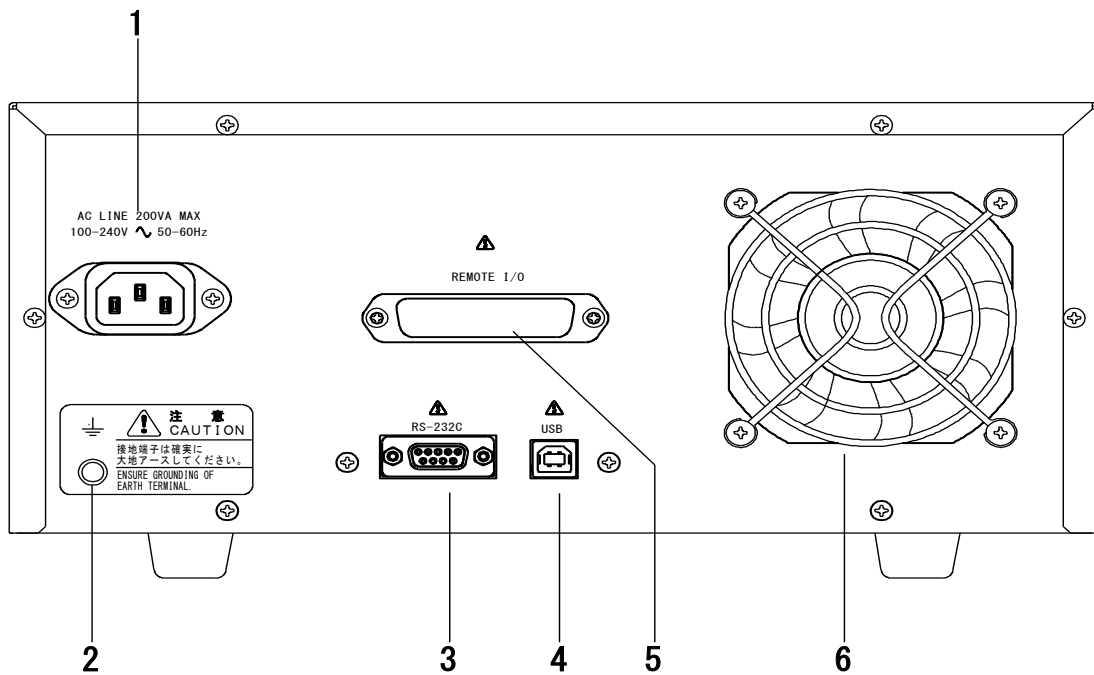

No.	Name	Function description
1	AC LINE connector	Supply power inlet
2	⏚	Protective earth terminal. Terminal for earthing the case of the tester with same potential
3	RS-232C connector	RS-232C interface
4	USB connector	USB interface
5	Remote I/O connector	Connector for external control
6	Cooling fan	Fan for exhaust

This page is blank.

---

---

## 2. Preparation before use

---

---

Connection of power cord..... 10

Connection of the protective earth terminal..... 10

Method of removing and mounting of key cover (option)..... 10

Connection to the external control equipment ..... 11

Connection of the high-voltage cable ..... 11

Power on and off..... 12

## Connection of power cord

---

- 1 Make sure that the power switch POWER of this tester is turned off.
  - 2 Connect the power cord to the inlet for the power supply of the rear face.  
The plug of the power cord that comes with this tester is for AC100V. If it exceeds AC125V, use the power cord suitable for the rating. 200V type power cord with a plug attached (European 2-pole with earth model name 5880-23-030) is optional.
  - 3 Power cord plug (3P) is connected to the earthed outlet.  
The plug of the power cord is 3-pin and the round shaped pin of the center is the earthing.
- 



### Warning

Use supply voltage AC100~AC240V (AC90~250V) and power frequency 50/60Hz. Besides, when you connect the power cord, make sure that the power switch is turned off. Beyond this range could lead to the failure and incomplete operation of the tester.

---

## Connection of the protective earth terminal

---

Earth the protective earth terminal ② to the ground using the supplied earthing wire. When the earthing is imperfect or when the output is short circuited to the ground or power line, the case of the tester is highly charged and it is dangerous to touch it. Besides, when using the tester, be sure to check that the earthing wire is not disconnected.

---



### Warning

If the earthing is imperfect, there is a risk of an electric shock.

---

## Method of removing and mounting of key cover (option)

---

You can mount the key cover (Model 5858-19) to the set up key as an option.  
It is used when the set value is not wanted to be processed. As it is fixed with knurled screws, removing and mounting can be done easily with your fingers.



---

## Connection to the external control equipment

---

External control equipment can be connected to the remote I/O connector ⑤  
Refer to “11.Remote I/O” for connection method.

2

---

## Connection of the high-voltage cable

---

During the test, the high voltage output terminal is charged to a high voltage. Connect the supplied high voltage cable with the HIGH VOLTAGE terminal and LOW terminal. For high voltage cable, use the supplied cable or cable adaptable for the voltage used.

---

### Warning

- Make sure to confirm the power off before connecting the high voltage cable. There is a risk of an electrical shock.
  - As the vinyl covering part of alligator clip of the supplied high voltage cable is not a withstand voltage, do not touch during the test. There is a risk of an electric shock.
- 

After connecting the low-voltage side cable to the LOW terminal ⑨, be sure to secure the retaining bracket to the terminal.

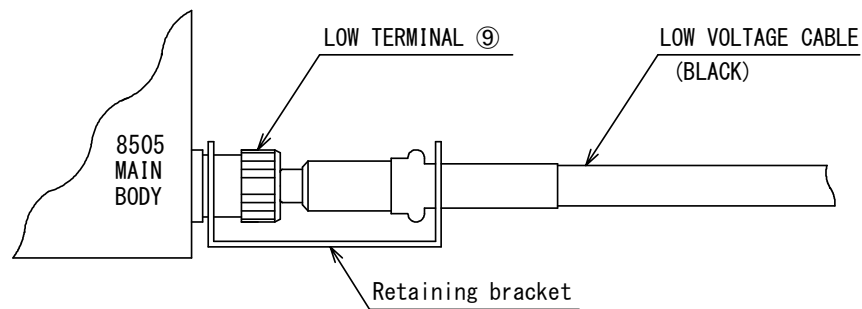

Tighten the low terminal of the main body with the U shaped groove side of the retaining bracket

---

### Warning

When the low voltage side cable is disconnected, the whole tested equipment gets charged with high voltage and there is a risk of an electric shock.

---

## Power on and off

---

After purchasing for the first time when POWER switch⑮ is on, the test begins and due to interlock function, the state becomes PROTECTION state. Connect the supplied remote I/O connector.

Use the supplied remote I/O connector only after the PROTECT state is released easily.

If you do the actual test, use the interlock function for the safety.

To guard the test area against the electric shock, use the interlock function like cut-off etc. when opening the door or cover.

- 1 Make sure that the power cord, connection cables etc. are connected properly.
- 2 Press “-” side of POWER switch ⑮ of front panel to turn it on.
- 3 After turning on the power switch, all lights on display are on for few seconds (lamp test). However, TEST VOLTAGE and CURRENT/RESISTANCE display firm version. After a few seconds, the display would be of test mode when the previous power was turned off.
- 4 Press “○” side of the POWER switch of the front panel to turn it off.



Do not turn off the POWER switch ⑮ during the test voltage output. This may cause a malfunction. However, it excludes in the state of emergency stop when voltage output does not decrease even when the STOP switch is pressed due to the abnormality of test sample etc.

---

---

---

## 3. Panel operation

---

---

Expression of the panel display of setting operation.....	14
Key Lock .....	14
Configuration of the display .....	15
Setting of test conditions .....	15
READY state .....	16
Display during the test.....	17
Display example of judgment result .....	17

## Expression of the panel display of setting operation

Depending on the key operation, the state of the display unit LED is expressed as below:

	Numerical Indicator	Surface-emitting LED Lamp	Round LED Lamp
On state			<input checked="" type="radio"/> ACW-IR
Blinking state			<input type="radio"/> ACW-IR
Off state			<input type="radio"/> ACW-IR



### Caution

During setting, if key is not operated for about five minutes, it automatically returns to READY state. During this time the contents changed will not be stored.

## Key Lock

With this operation, the setting key operation is disabled.

At this time, only START switch and STOP switch are enabled in front panel operation.

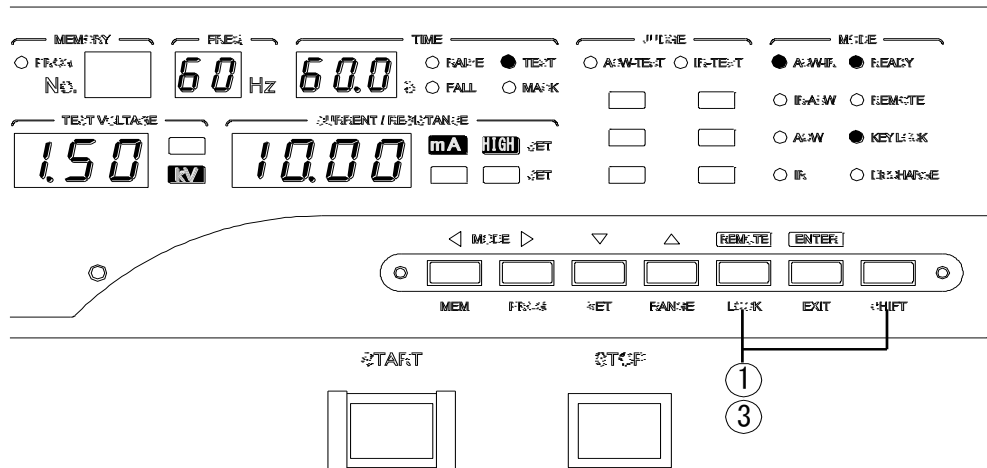

- Setting of Key Lock
- ① Press LOCK key (pressing the LOCK while holding down the SHIFT) for 3 seconds in the READY state.
  - ② KEY LOCK lamp is lit and the key lock function is set.
- Release of Key Lock
- ③ Press LOCK key (pressing the LOCK while holding down the SHIFT) for 3 seconds till KEY LOCK lamp is off.

# Configuration of the display

The front panel display of this tester can be broadly divided into four parts. The setting of test conditions can be done in accordance to the objectives like application of memory operation, program operation and other functions.

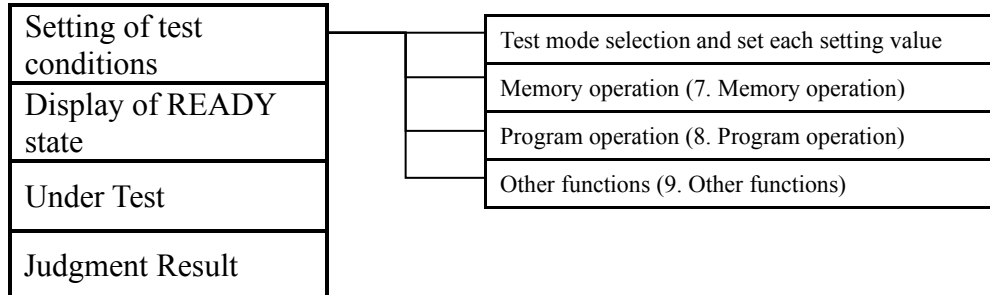

## Setting of test conditions

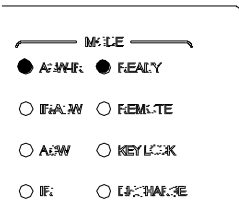

It shows the test mode that is currently selected.

Panel display	Test Mode
ACW-IR	Withstand voltage test → Insulation test
IR-ACW	Insulation test → Withstand voltage test
ACW	Withstand voltage test
IR	Insulation test

### Setting Method

For detail refer “4. Setting of independent test and automatic test”, “5. Setting of withstand voltage test conditions” and “6. Setting of insulation test conditions”.

## READY state

- 1) When the POWER switch ⑮ is turned on, after displaying firmware version for a few seconds, READY lamp turns on and becomes READY state.
- 2) READY lamp is on in the state where the test can be started.
- 3) When setting the test conditions etc. READY lamp turns off.
- 4) In the automatic test mode (ACW-IR, IR-ACW), the test conditions setting of withstand voltage test and insulation resistance test are displayed alternately.

Withstand voltage test  
( ACW )

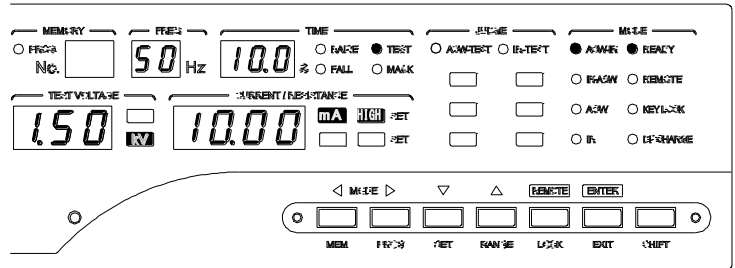

↕ Display alternately (During ACW-IR, IR-ACW)

Insulation resistance test  
( IR )

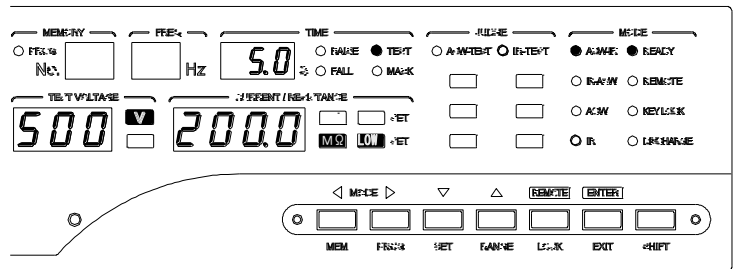

### Panel setting mode is

When MEMORY, PROG display are off, "Panel setting mode" is written.

# Display during the test

During withstand voltage test,  
DANGER lamp is turned on and test voltage value and leakage current value are displayed.

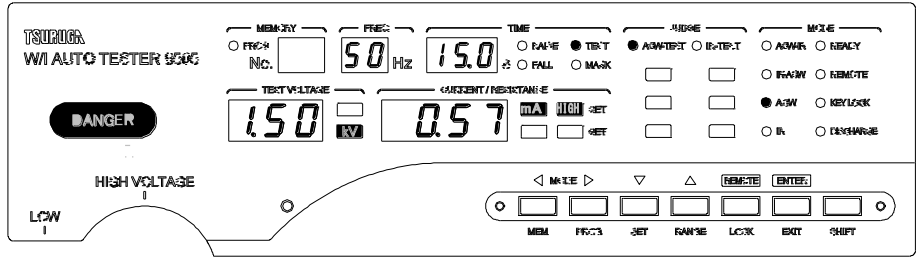
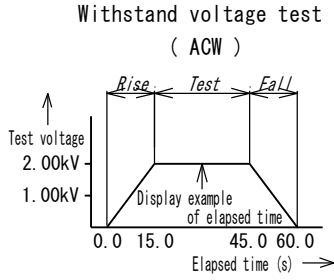

3

During insulation resistance test,  
DANGER lamp is turned on and test voltage range and insulation resistance value are displayed.

Insulation resistance test (IR)

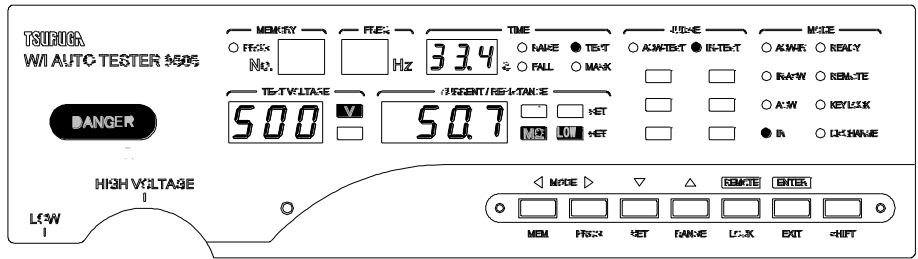

# Display example of judgment result

Display example during automatic test (IR-ACW), when IR, ACW and GOOD judgment are done.

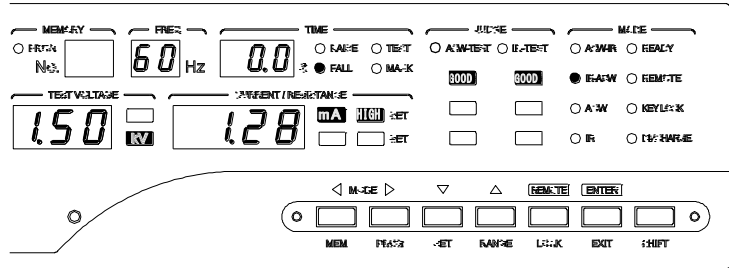

Display example during automatic test (ACW\_IR), when GOOD judgment in ACW and NG judgment in IR are done.

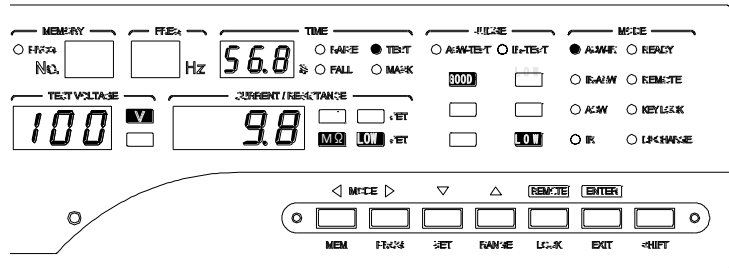

This page is blank.



---

---

## **4. Setting of a single test and an automatic test**

### **(ACW→IR, IR→ACW)**

---

---

Types of test.....	20
Selection of test mode.....	21

## Types of test

---

This tester has a single test and an automatic test.

1) Single test

- Withstand voltage test (ACW)
- Insulation resistance test (IR)

2) Automatic test

The withstand voltage test and insulation resistance test are switched to each other automatically and the test is carried out continuously.

- Switch to insulation resistance test from withstand voltage test (ACW-IR)
- Switch to withstand voltage test from insulation resistance test (IR-ACW)

## Selection of test mode

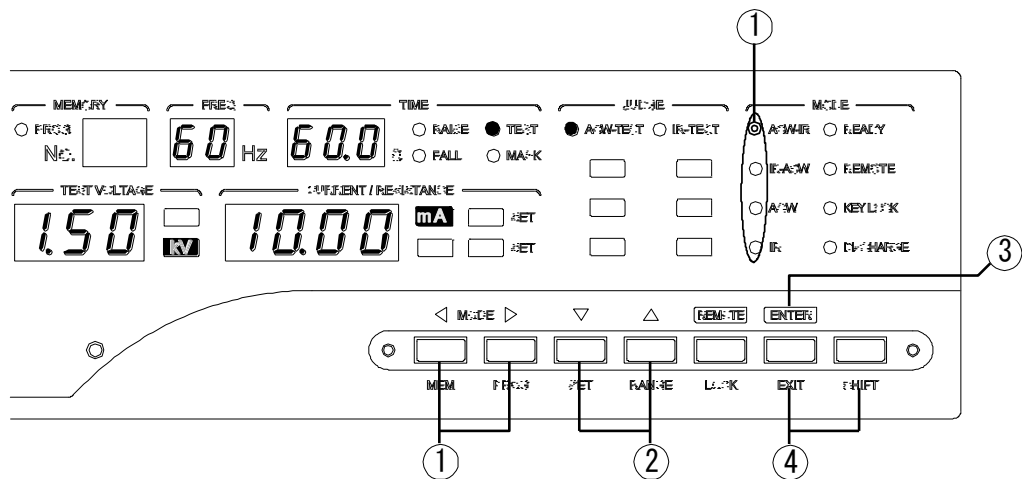

4

Enter in mode selection

① Press MODE key ( or ).

• Test mode lamp of MODE display blinks.

Selection of the test

② Selection is done by and keys.

Automatic test by the blinking of ACW-IR lamp from withstand voltage test to insulation resistance test.

Automatic test by the blinking of IR-ACW lamp from insulation resistance test to withstand voltage test.

Withstand voltage test by blinking of ACW lamp.

Insulation resistance test by blinking of IR lamp.

• Switching to the setting of test conditions by or key.

End of the selection

③ Press ENTER key and the setting is stored and returns to the READY state.

Interruption of the selection

④ If EXIT key (Holding down SHIFT and press EXIT) is pressed, the operation is interrupted, becomes READY state and the state is the one before entering the operation.

This page is blank.

---

---

## 5. Setting of withstand voltage test conditions

---

---

Setting of test voltage .....	24
Upper limit judgment value .....	25
Lower limit judgment value.....	26
Setting of the voltage rise time (rise time) .....	27
Setting of the voltage fall time (fall time).....	28
Setting of the test time .....	29
Setting of test voltage frequency.....	30

## Setting of test voltage

Single test ACW, automatic test ACW-IR, and withstand voltage test conditions of IR-ACW are set.  
 Test voltage is set.  
 Setting range : 0.00kV~5.50kV

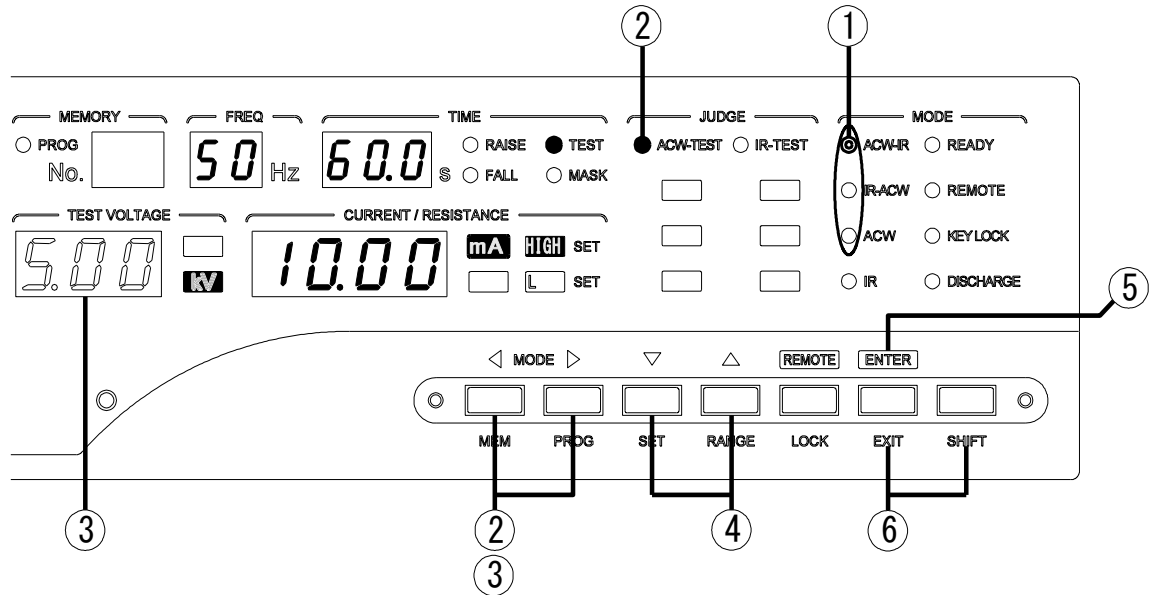

Enter in setting mode

- ① Select the test mode. ACW-IR, IR-ACW, ACW
- ② Press or key.  
 • ACW-TEST lamp of JUDGE display turns on.

Setting of test voltage

- ③ Press key.  
 The number of TEST VOLTAGE display blinks.
- ④ Test voltage is set using and keys.

Switching of test conditions

- Switch to the other conditions using or key.

End of setting

- ⑤ Press the ENTER key to store the settings and return to the READY state.

Interruption of setting

- ⑥ When EXIT key (Hold down SHIFT and EXIT) is pressed, the operation is interrupted, becomes READY state and the state is the one before entering the operation.

### Setting flow of withstand voltage test

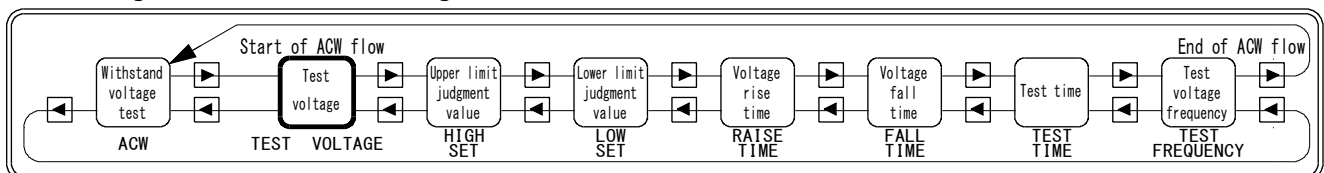

# Upper limit judgment value

Upper limit value of the judgment is set.  
Setting range : 0.01 ~ 20.00mA

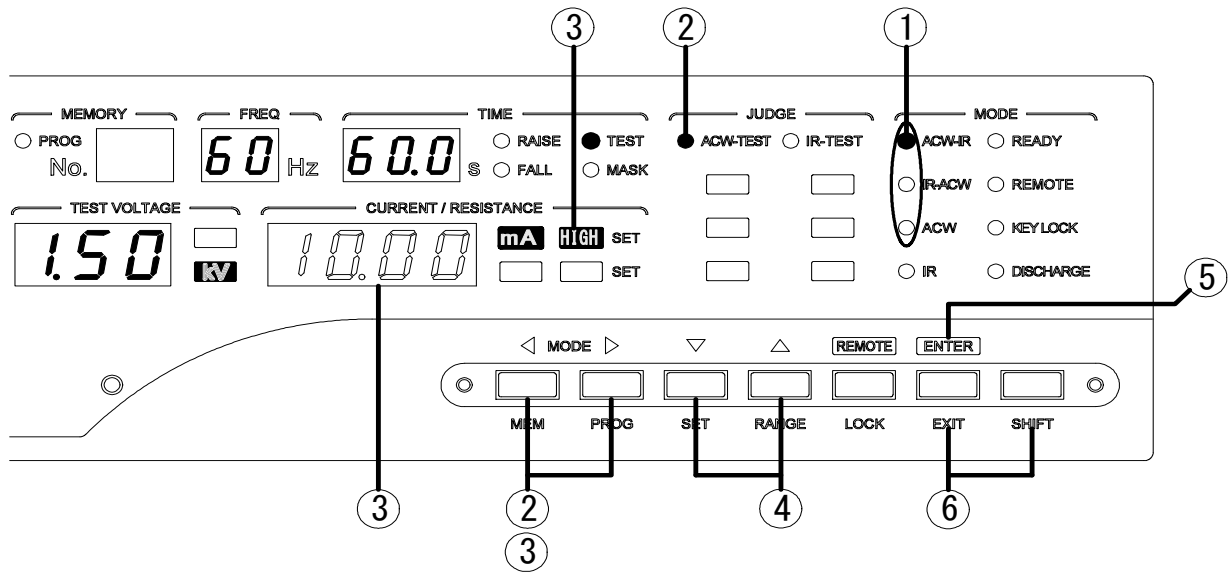

5

Enter in setting mode

- ① Select the test mode ACW-IR, IR-ACW, ACW
- ② Press ◀ or ▶ key.  
• ACW-TEST lamp of JUDGE display is turned on.

Setting of upper limit judgment value

- ③ Press ◀ or ▶ key.  
• The number of CURRENT display blinks and HIGH is turned on.
- ④ Upper limit judgment value is set by ▲ and ▼ keys.

Switching of test conditions

Switch to other setting conditions using ◀ or ▶ key.

End of the setting

- ⑤ Press the ENTER key to store the settings and return to the READY state.

Interruption of the setting

- ⑥ When EXIT key (Hold down SHIFT and EXIT) is pressed, the operation is interrupted, becomes READY state and the state is the one before entering the operation.

## Setting flow of withstand voltage test

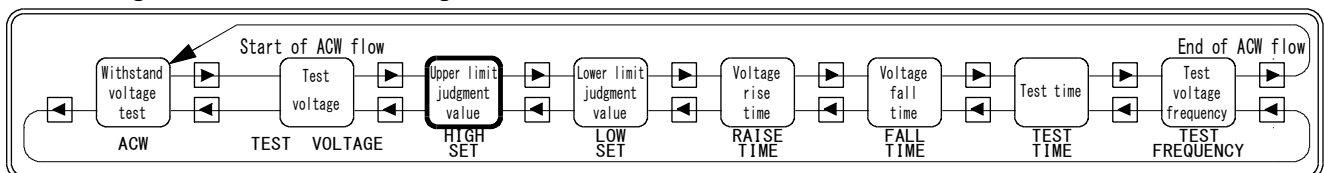

## Lower limit judgment value

- Lower limit value of the judgment is set. It is turned off when setting is not required.
- Lower limit judgment is not performed during voltage rise and voltage fall.
- Setting range : 0.01~19.99mA and OFF

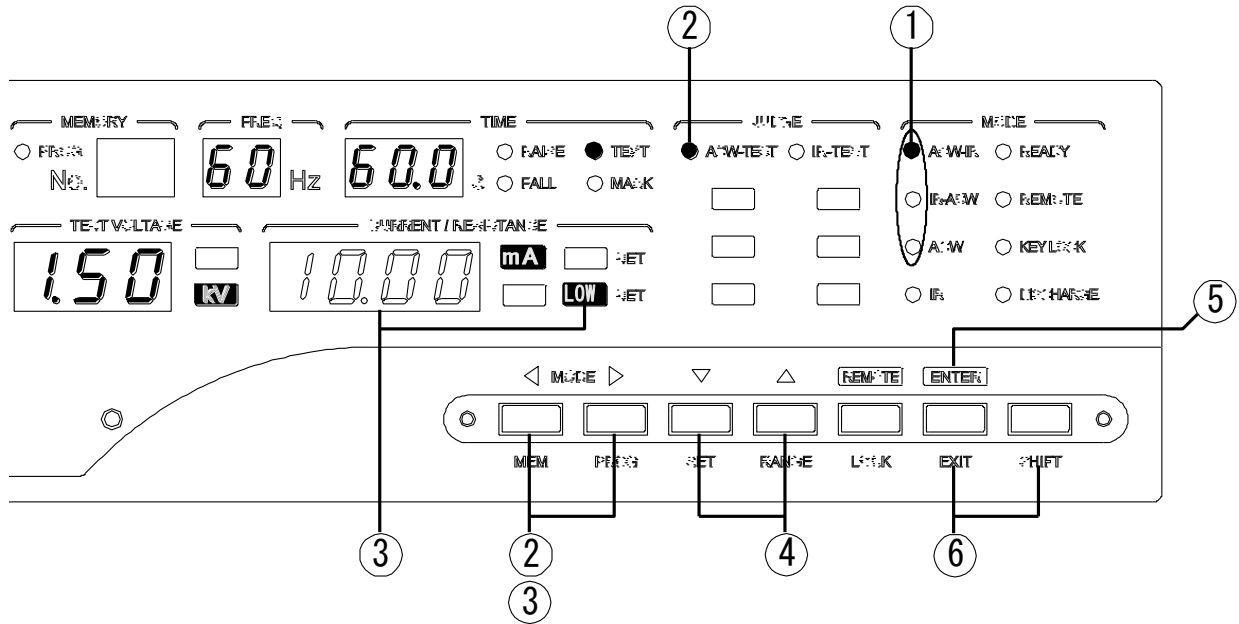

Enter in setting mode

- ① Select the test mode. ACW, ACW-IR, IR-ACW
- ② Press or key.
  - ACW-TEST lamp of JUDGE display is turned on.

Setting of lower limit judgment

- ③ Press or key.
  - The number of CURRENT display blinks and LOW is turned on.
- ④ Setting of lower limit judgment value is done by and keys.
  - Setting of OFF is done by pressing key continuously.

Switching of test conditions

Switch to the other setting conditions using or key.

End of the setting

- ⑤ Press the ENTER key to store the settings and return to the READY state.

Interruption of the setting

- ⑥ When EXIT key (Hold down SHIFT and EXIT) is pressed, the operation is interrupted, becomes READY state and the state is the one before entering the operation.

### Setting flow of withstand voltage test

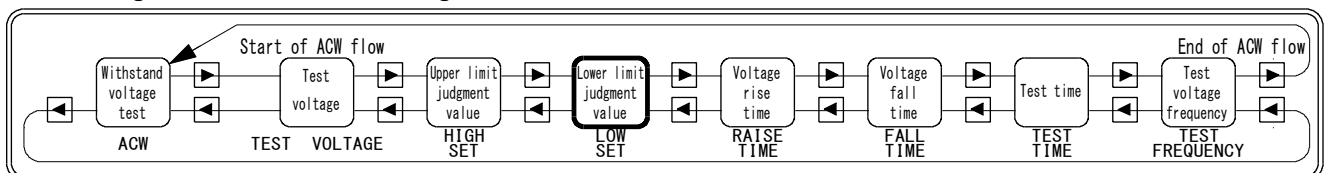



## Setting of the voltage rise time (rise time)

- Voltage rise time is set till it reaches the test voltage value.
- During the voltage rise, the lower limit judgment of leakage current is not performed.
- Setting range : 0.1 ~ 99.9/100 ~ 999 seconds

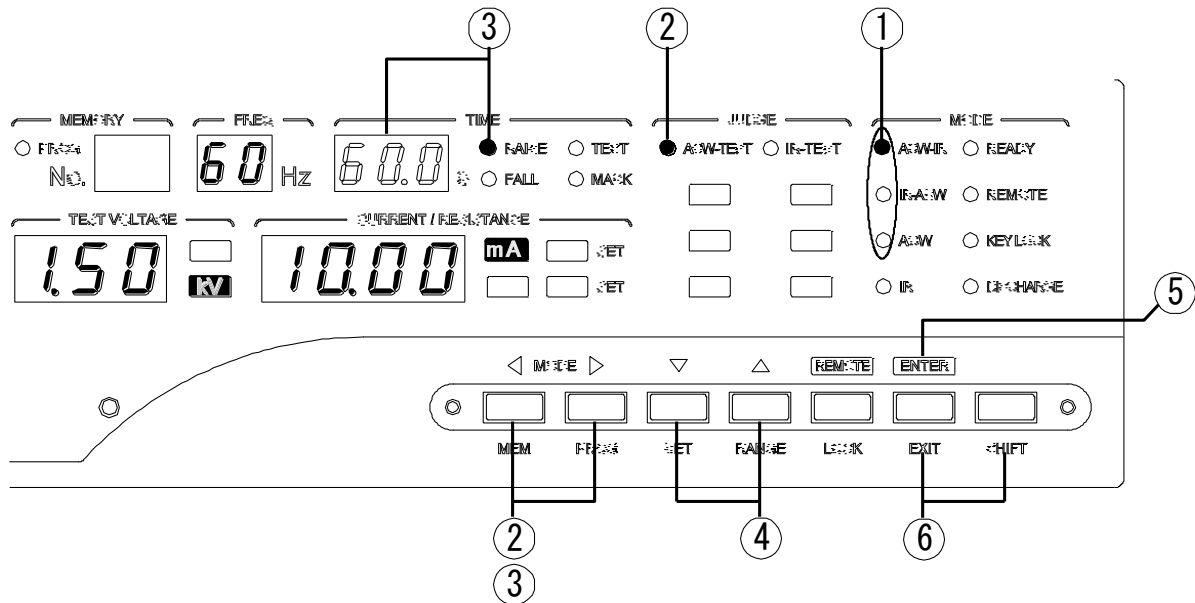

5

Enter in the setting mode

- ① Select the test mode. ACW-IR, IR-ACW, ACW
- ② Press or key.

• ACW-TEST lamp of JUDGE display is turned on.

Setting the voltage rise time

- ③ Press or key.
- Numeric display of TIME display blinks and RAISE lamp displays light.
- ④ Select the position of the decimal point by RANGE key( RANGE holding down the SHIFT).  
Set the number value using and key.

Switching of test conditions

- Switch to the other setting conditions using or key.

End of Setting

- ④ Press the ENTER key to store the settings and return to the READY state.

Interruption of setting

- ⑥ When EXIT key (Hold down SHIFT and EXIT) is pressed, the operation is interrupted, becomes READY state and the state is the one before entering the operation.

### Setting flow of withstand voltage test

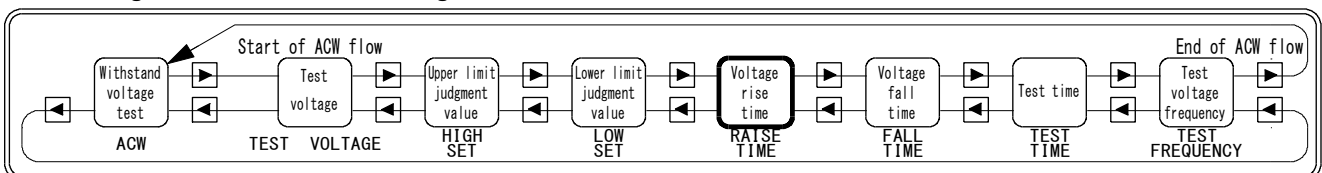

## Setting of the voltage fall time (fall time)

- Fall time of the test voltage is set.
- During the voltage fall, the lower limit judgment of leakage current is not performed.
- Setting range : 0.1~99.9/100~999 seconds and OFF

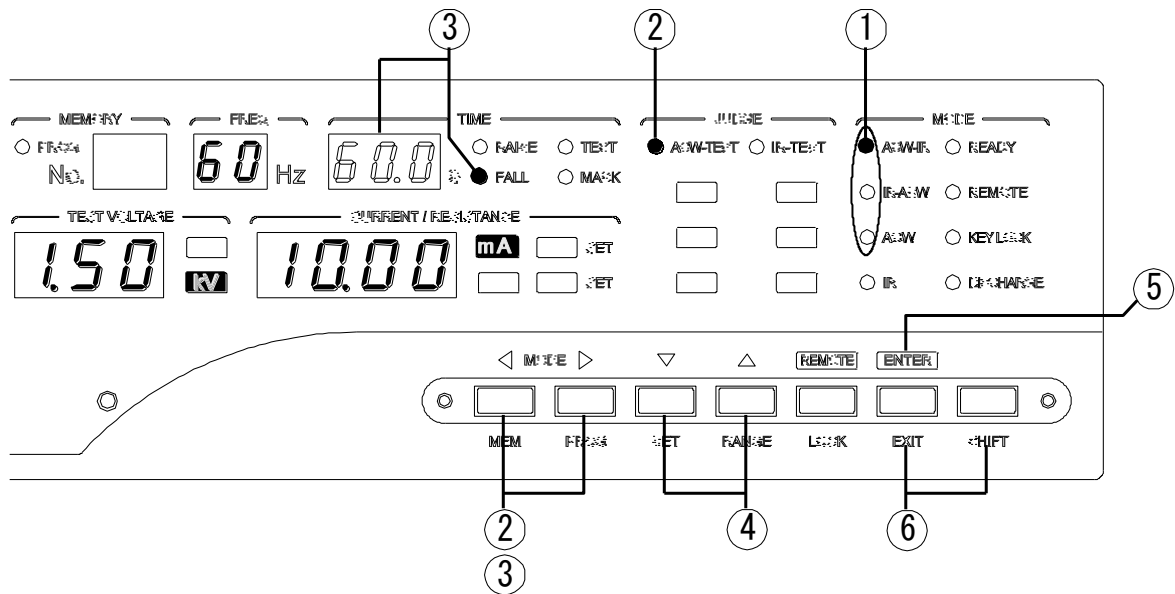

Enter in setting mode

- ① Select the test mode. ACW-IR, IR-ACW, ACW

- ② Press or key.

• ACW-TEST lamp of JUDGE display turns on.

Setting of the voltage fall time

- ③ Press or key.

• Numeric display of TIME display blinks and FALL lamp displays light.

- ④ Select the position of the decimal point or OFF by RANGE key (RANGE holding down the SHIFT).

Set the fall time using and keys.

Switching of the test conditions

Switch to the other setting conditions using or key.

End of setting

- ⑤ Press the ENTER key to store the settings and return to the READY state.

Interruption of setting

- ⑥ When EXIT key (Hold down SHIFT and EXIT) is pressed, the operation is interrupted, becomes

READY state and the state is the one before entering the operation.

### Setting flow of withstand voltage test

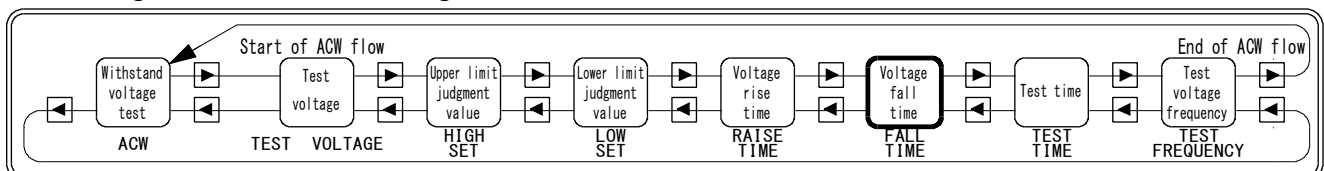

# Setting of the test time

- Setting range : 0.1~99.9/100~999 seconds and OFF
  - If the test time is set, timer display counts down during the test.
  - If the test time is put OFF, the timer display counts up from the test start.
- If it exceeds 999, " — — — " is displayed and test continues till NG judgment or stop.

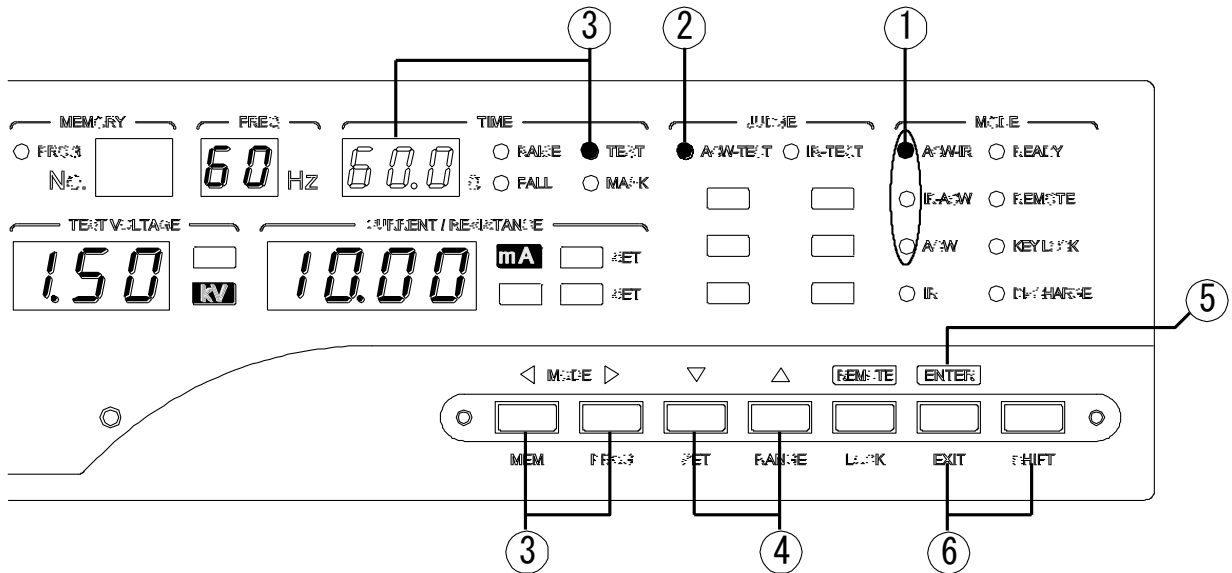

5

### Enter in setting mode

- ① Select the test mode. ACW, ACW-IR, IR-ACW
- ② Press or key.
  - ACW-TEST lamp of JUDGE display turns on.

### Setting of test time

- ③ Press or key.
  - Numeric display of TIME display blinks and TEST lamp displays light.
- ④ Select the position of the decimal point or OFF by RANGE key (RANGE holding down the SHIFT). Set the test time using and key.

### Switching of test conditions

Switch to the other setting conditions using or key.

### End of setting

- ⑤ Press the ENTER key to store the settings and return to the READY state.

### Interruption of setting

- ⑥ When EXIT key (HOLD down SHIFT and EXIT) is pressed, the operation is interrupted, becomes READY state and the state is the one before entering the operation.

### Setting flow of withstand voltage test

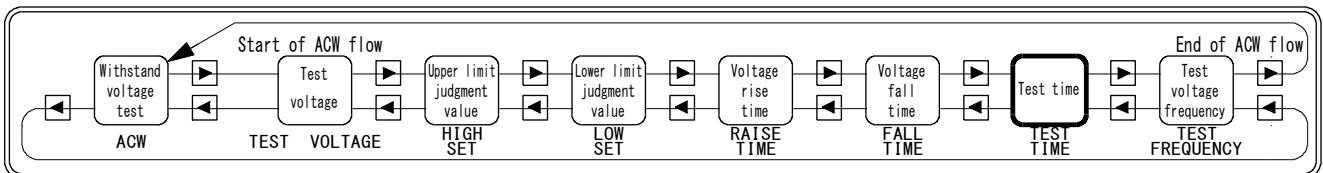

## Setting of test voltage frequency

• Frequency possible : 50Hz and 60Hz

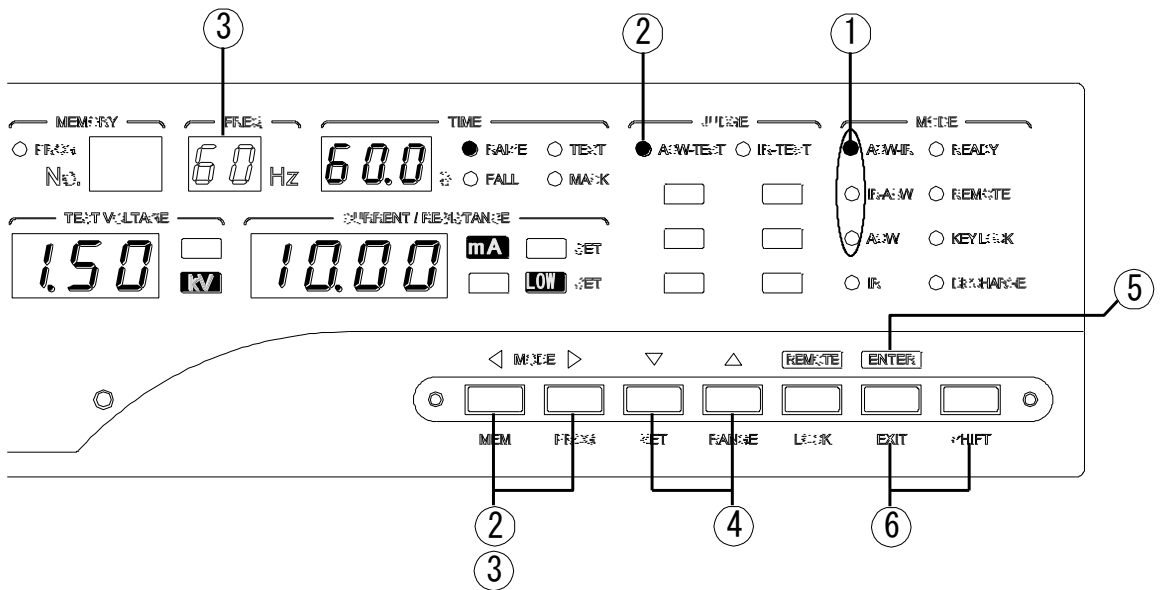

Enter in setting mode

- ① Select the setting mode. ACW-IR, IR-ACW, ACW
- ② Press  or  key.  
• ACW-TEST lamp of JUDGE display turns on.

Setting of the frequency of the test voltage

- ③ Press  or  key.  
• Numeric display of FREQ display blinks.
- ④ Select the frequency using  and  keys.

Switching of test conditions

Switch to the other setting conditions using  or  key.

End of setting

- ⑤ Press the ENTER key to store the settings and return to the READY state.

Interruption of setting

- ⑥ When EXIT key (Hold down SHIFT and EXIT) is pressed, the operation is interrupted, becomes READY state and the stage is the one before entering the operation.

### Setting flow of withstand voltage test

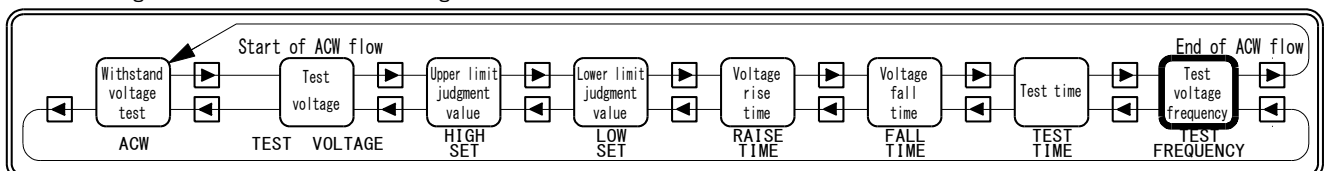

---

---

# 6. Setting of insulation resistance test (IR) conditions

---

---

Setting of test voltage ..... 32  
Setting of resistance range ..... 33  
Upper limit judgment and lower limit judgment value ..... 34  
Setting of mask time ..... 35  
Setting of test time ..... 36

## Setting of test voltage

Set a single test IR, automatic test ACW-IR and insulation resistance test conditions in IR-ACW.  
 Set the test voltage.  
 Setting range : 25V, 50V, 100V, 250V, 500V, 1.00kV

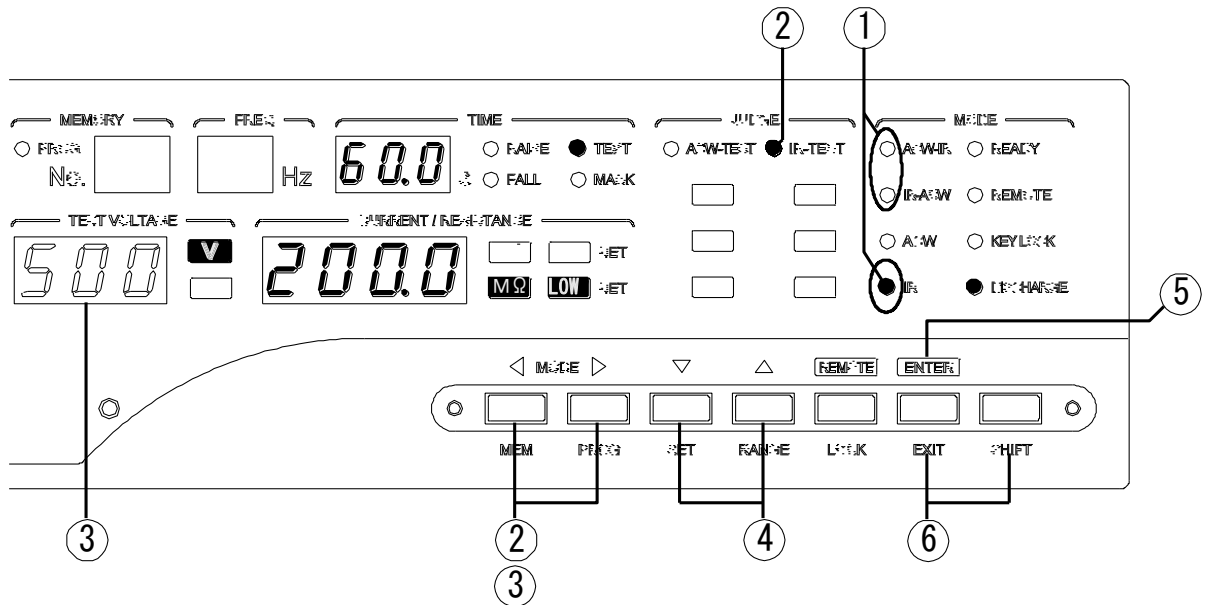

Enter in setting mode

- ① Select the test mode. ACW-IR, IR-ACW, IR
- ② Press  or  key.
- IR-TEST lamp of JUDGE display is turned on.

Setting of the test voltage

- ③ Press  key.
- Select the number blinking display of TEST VOLTAGE display.
- ④ Select the test voltage using  and  keys.

Switching of test conditions

Switch to the other setting conditions using  or  key.

End of setting

- ⑤ Press the ENTER key to store the settings and return to the READY state.

Interruption of setting

- ⑥ When EXIT key (Hold down SHIFT and EXIT) is pressed, the operation is interrupted, becomes READY state and the state is the one before entering the operation.

### Setting flow of insulation resistance test

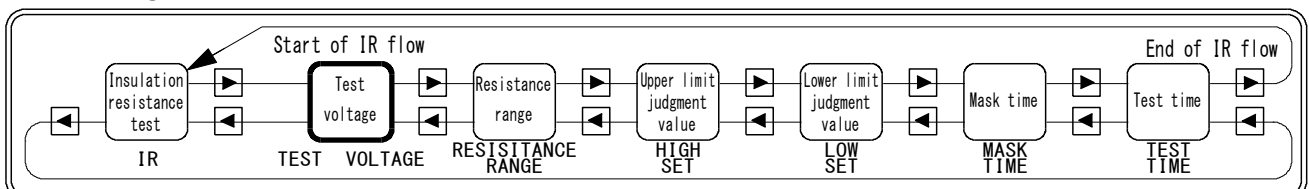

## Setting of resistance range

Set the resistance range.

Setting range : 2.000MΩ , 20.00MΩ , 200.0MΩ , 2000MΩ , AUTO

※Refer specification column for setting range

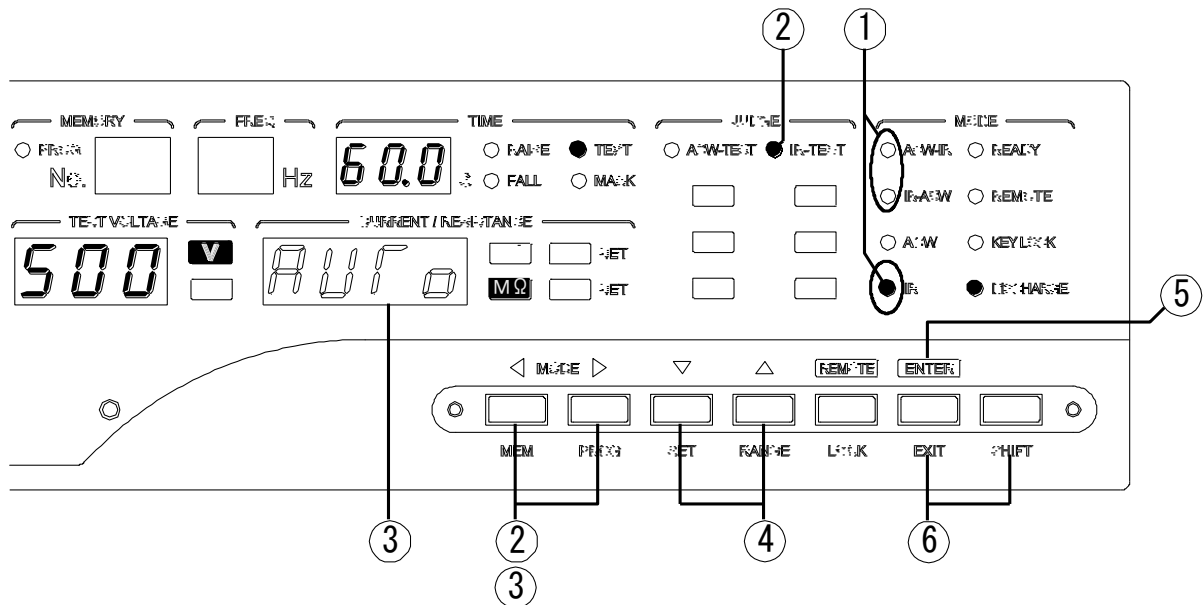

Enter in setting mode

① Select the test mode. ACW-IR, IR-ACW, IR

② Press or key.

•IR-TEST lamp of JUDGE display is turned on.

Select a resistance range

③ Press or key.

•MΩ is lit and select the number blinking display of RESISTANCE display.

④ Select resistance range using and keys.

Switching of test conditions

Switch to the other setting conditions using or key.

End of setting

⑤ Press the ENTER key to store the settings and return to the READY state.

Interruption of setting

⑥ When EXIT key (Hold down SHIFT and EXIT) is pressed, the operation is interrupted, becomes READY state and the state is the one before entering the operation.

### Setting flow of insulation resistance test

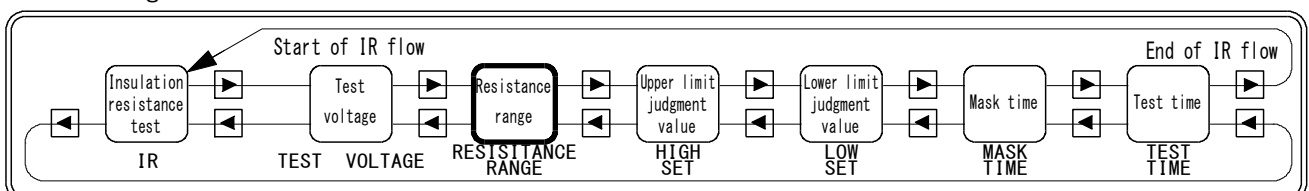

## Upper limit judgment and lower limit judgment value

- Set the judgment value of the insulation resistance.
- Setting range: 0.001~9990

Comparison condition

- Display value  $\geq$  Upper limit judgment value (HIGH)      HIGH (HI) output  
 Upper limit judgment value (HIGH) > display value > Lower limit judgment value (LOW)      GOOD (GO) output  
 Display value  $\leq$  Lower limit judgment value (LOW)      LOW (LO) output

Note: The judgment of upper limit judgment value is not performed during OFF possible mask time.

### Setting of upper limit judgment value and lower limit judgment value

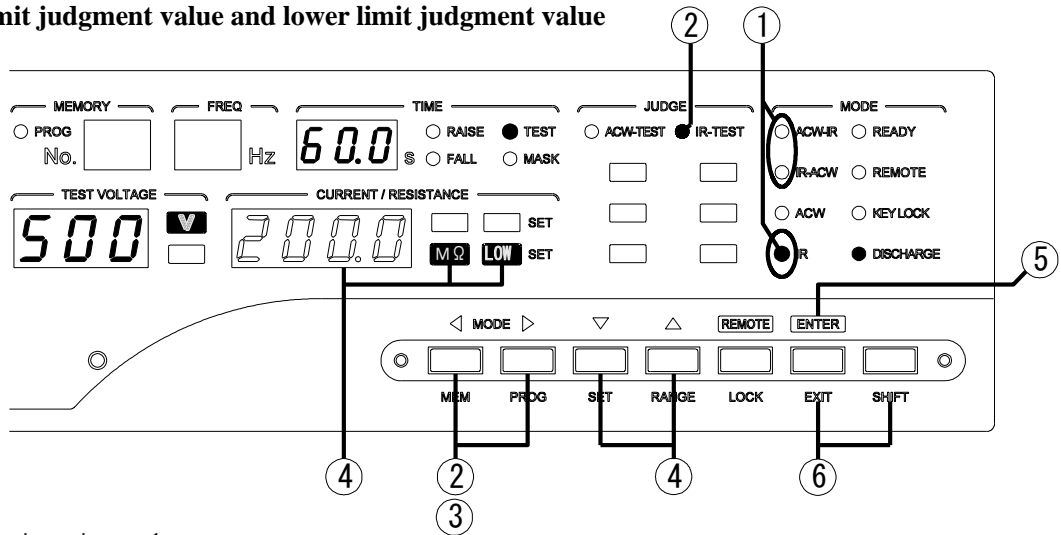

Enter in setting mode

- ① Select the test mode. ACW-IR, IR-ACW, IR
- ② Press or key
- IR\_TEST lamp of JUDGE display is turned on.

Setting of judgment value

- ③ Press or key.
- Numbers of RESISTANCE display blinks, select the lighting of HIGH or LOW.
  - HIGH Lighting: Perform the setting of high limit judgment value.
  - LOW Lighting: Perform the setting of low limit judgment value.
- ④ Select the position of the decimal point by RANGE key (RANGE holding down the SHIFT) or OFF. Set the value using and keys. When continue pressing, the speed of increase and decrease of numerical value will be faster.
- It is not possible to set the lower limit value to OFF.

Switching of test conditions

- Switch to the other setting conditions using or key.

End of setting

- ⑤ Press the ENTER key to store the settings and return to the READY state.

Interruption of setting

- ⑥ When EXIT key (Hold down SHIFT and EXIT) is pressed, the operation is interrupted, becomes READY state and the state is the one before entering the operation.

### Setting flow of insulation resistance test

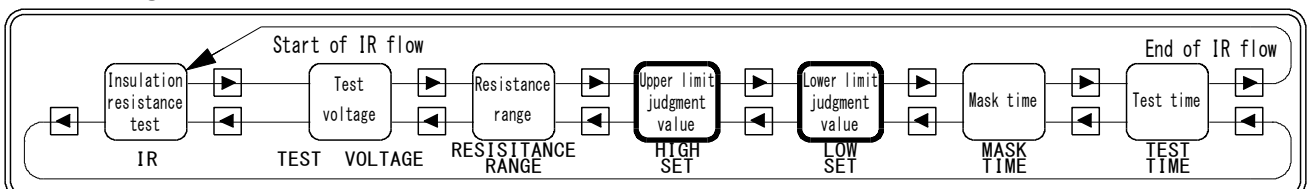



## Setting of mask time

- It is a timer to prohibit the judgment from the start of the test for a certain period of time. MASK lamp is turned on during timer operation. It is used when the waiting time is important for the measurement of test specimen which has delay like capacitive load etc.
- Setting range : 0.1 ~ 99.9 seconds. Not possible during OFF.

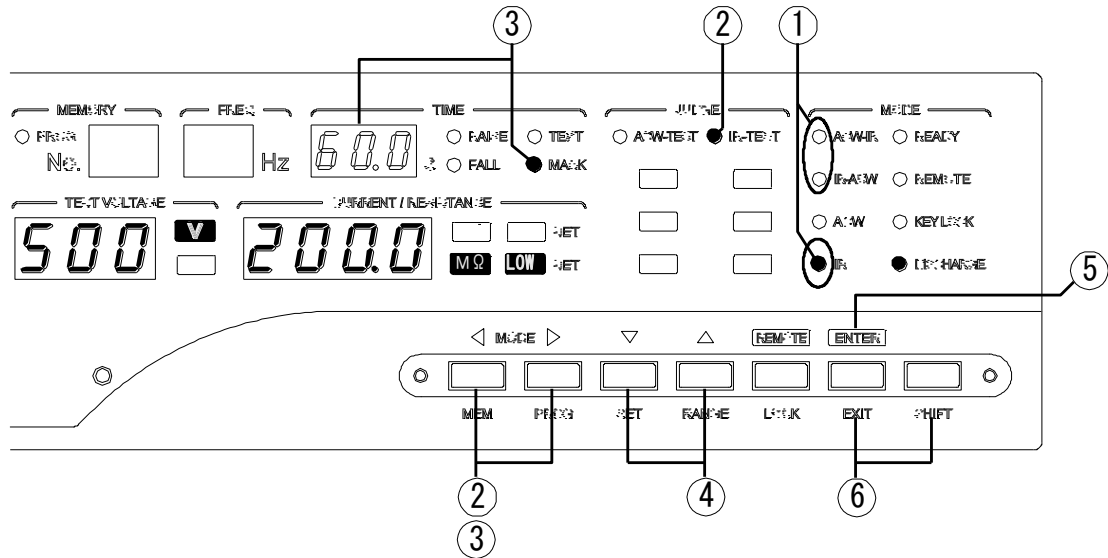

Enter in setting mode

- ① Select the test mode. ACW-IR, IR-ACW, IR
- ② Press or key.  
• IR-TEST lamp of JUDGE display is turned on.

Setting of mask time

- ③ Press or key.  
• Numeric display of TIME display blinks and MASK lamp displays light.
- ④ Set the mask time using and keys.

Switching of the setting item

Switching to the other setting conditions using or key.

End of setting

- ⑤ Press the ENTER key to store the settings and return to the READY state.

Interruption of setting

- ⑥ When EXIT key (Hold down SHIFT and EXIT) is pressed, the operation is interrupted, becomes READY state and the state is the one before entering the operation.

### Setting flow of insulation resistance test

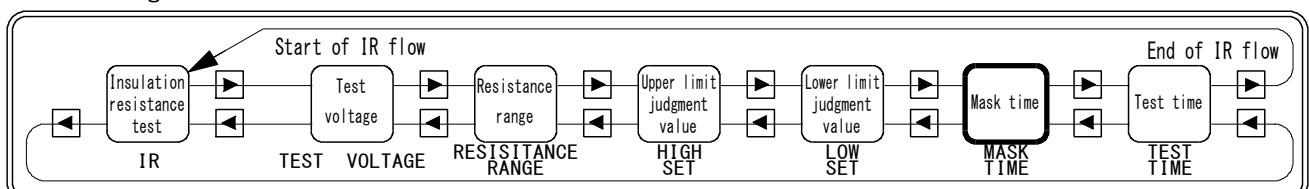

## Setting of test time

- Set the test time
- Setting range : 0.2~99.9 seconds

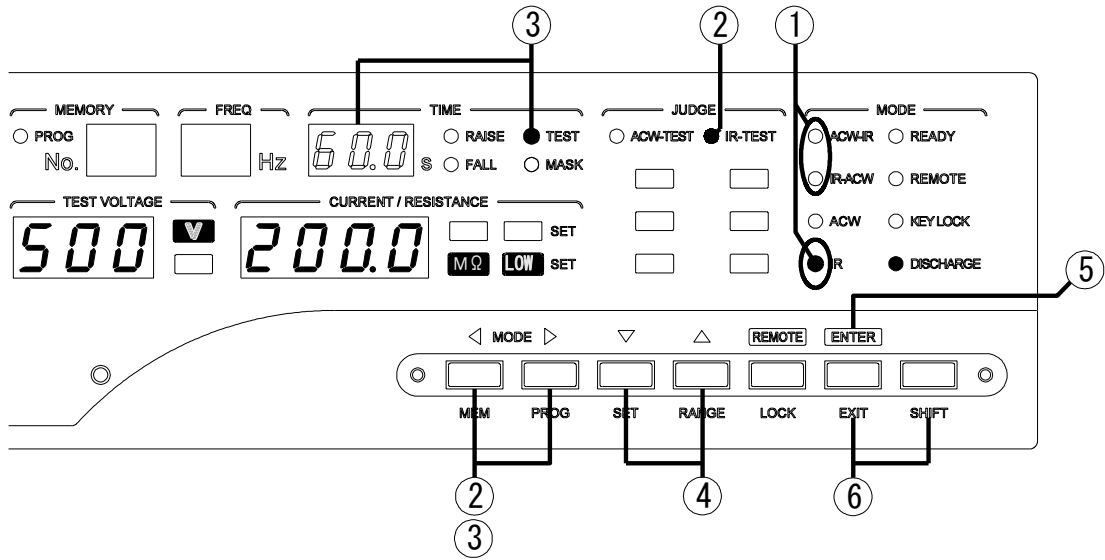

Enter in setting mode

- ① Select the setting mode. ACW-IR, IR-ACW, IR
- ② Press or key.  
• IR-TEST lamp of JUDGE display is turned on.

Setting of test time

- ③ Press or key.  
• Numerical display of TIME display blinks and TEST lamp displays light.
- ④ Set the test time using and keys.

Switching of the setting item

Switch to the other setting conditions using or key.

End of setting

- ⑤ Press the ENTER key to store the settings and return to the READY state.

Interruption of setting

- ⑥ When EXIT key (Hold down SHIFY and EXIT) is pressed, the operation is interrupted, becomes READY state and the state is the one before entering the operation.

### Setting flow of insulation resistance test

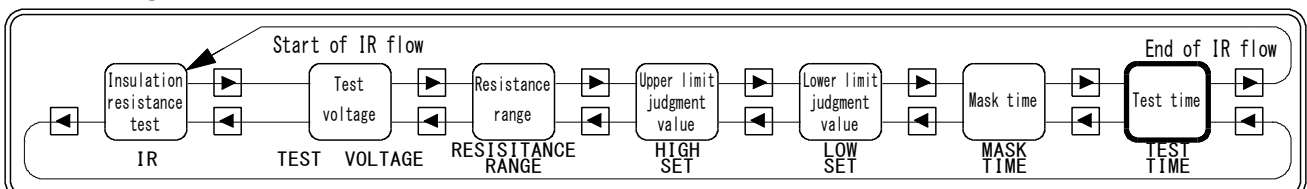

---

---

## 7. Memory operation

---

---

Overview .....	38
Call and setting of memory.....	39

## Overview

- The test conditions up to maximum 16 pairs can be memorized in the internal memory.
- The memorized content can be called by an external control and remote control.

Test conditions that can be stored

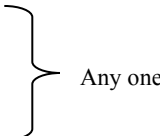
Setting items	Test conditions
Test mode	ACW → IR IR → ACW ACW IR  Any one
Withstand voltage test ACW	Test voltage Upper limit judgment value Lower limit judgment value Voltage rise time Voltage fall time Test time The frequency of the test voltage
Insulation resistance test IR	Test voltage Resistance range Upper limit judgment value Lower limit judgment value Mask timer time Test time

# Call and setting of memory

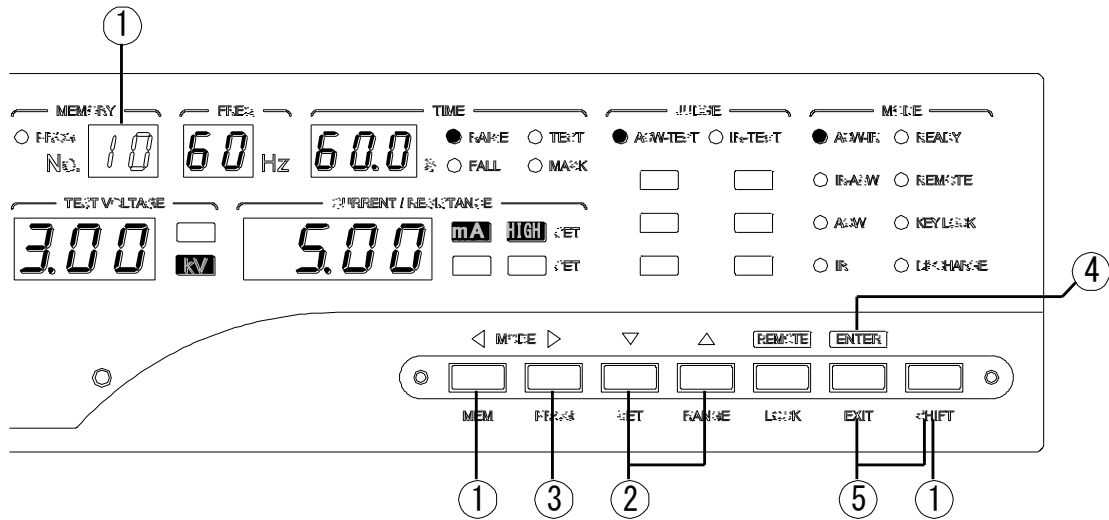

## Call of memory

- ① Press MEM key (Hold down SHIFT and MEM) at READY state.
  - Memory No. blinks in the MEMORY display.

## Selection of memory No.

- ② Select the number using  $\blacktriangle$  and  $\blacktriangledown$  keys.
  - Test conditions of the number selected are displayed.
  - Numbers: 1~16

## Confirmation and setting of test conditions

- ③ Enter the setting and confirmation of test conditions after deciding memory No. using  $\blacktriangleright$  key.
  - Refer “5. Setting the withstand voltage test (ACW) conditions” and “6. Setting the insulation resistance test (IR) conditions” for flow of the item.

## End of the call

- ④ Press the ENTER key to store the setting and return to the READY state.

## Interruption

- ⑤ When EXIT key (Hold down SHIFT and EXIT) is pressed, the operation is interrupted, becomes READY state and the state is the one before entering the operation.

## Setting item of withstand voltage test

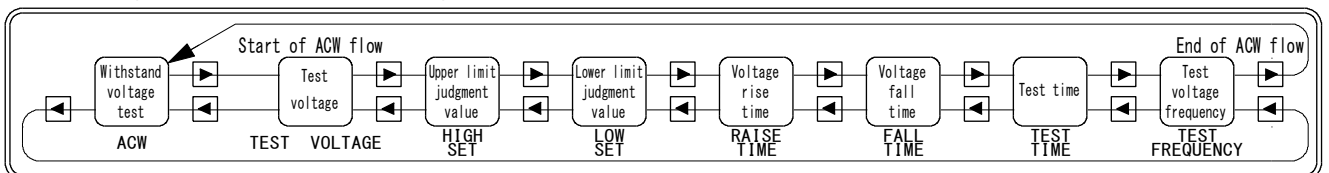

## Setting item of insulation resistance test

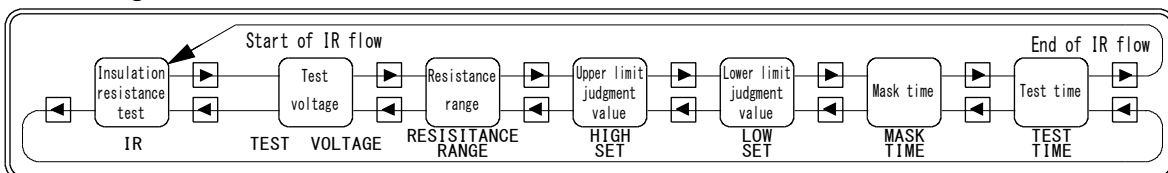

This page is blank.

---

---

## 8. Program operation

---

---

Overview .....	42
Flow of program operation .....	43
Call of program operation.....	44
Setting of the program .....	45

## Overview

Withstand voltage test (ACW) is the only test condition where program is possible. There are 16 programs from 0~F, setting of maximum 16 test conditions of each step in one program and continuous test is possible.

Example:

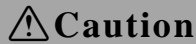
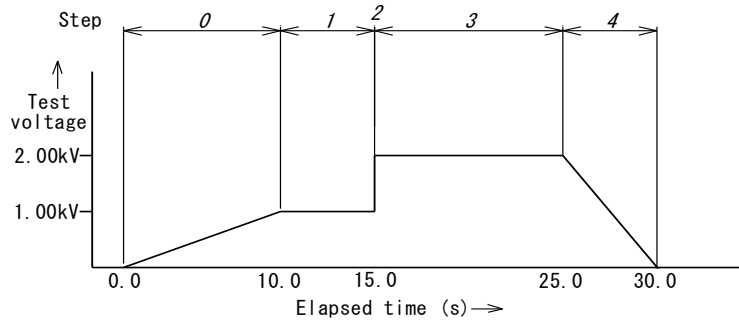

### Caution

Step 0 (rising section) and step 4 (falling section) are done only in upper limit judgment. Lower limit judgment is not performed.

Like section 1 and section 3, the test voltage is performed in a certain interval or together with upper limit judgment and lower limit judgment.

Step No.	Next step	Test voltage (kV)	Timer Time (s)	Upper limit judgment value (mA)	Lower limit judgment value (mA)	Remarks
0	ON	1.00	10.0	10.00	2.00	From 0kV to 1kV after 10 seconds
1	ON	1.00	5.0	10.00	2.00	Maintain 1kV for 5 seconds
2	ON	2.00	0.1	10.00	2.00	Rising from 1kV to 2kV
3	ON	2.00	10.0	10.00	2.00	Maintain 2kV for 10 seconds
4	END	0.00	5.0	10.00	2.00	From 2kV to 0kV after 5 seconds
5	ON	0.00	0.1	0.50	OFF	At the "END", test is completed with this step.
6	ON	0.00	0.1	0.50	OFF	
7	ON	0.00	0.1	0.50	OFF	
8	ON	0.00	0.1	0.50	OFF	
9	ON	0.00	0.1	0.50	OFF	
A	ON	0.00	0.1	0.50	OFF	
B	ON	0.00	0.1	0.50	OFF	
C	ON	0.00	0.1	0.50	OFF	
D	ON	0.00	0.1	0.50	OFF	
E	ON	0.00	0.1	0.50	OFF	
F	END	0.00	0.1	0.50	OFF	

At the end of the sentence, there is memo of program operation for customers, so use it.



# Flow of program operation

It shows the flow of setting of program operation of the withstand voltage test from the start to the end. For explanation besides step numbers refer to the following pages.

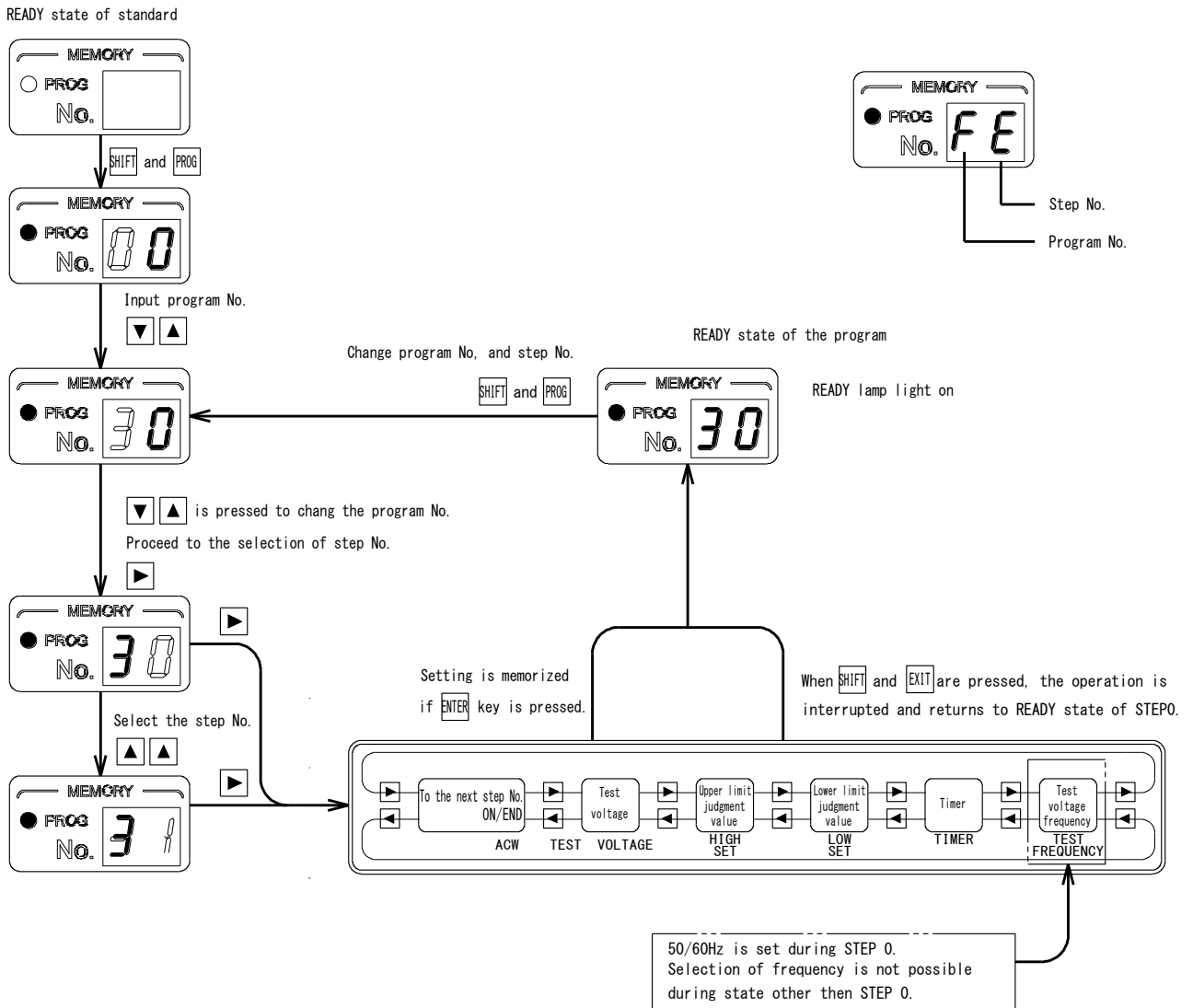

## Call of program operation

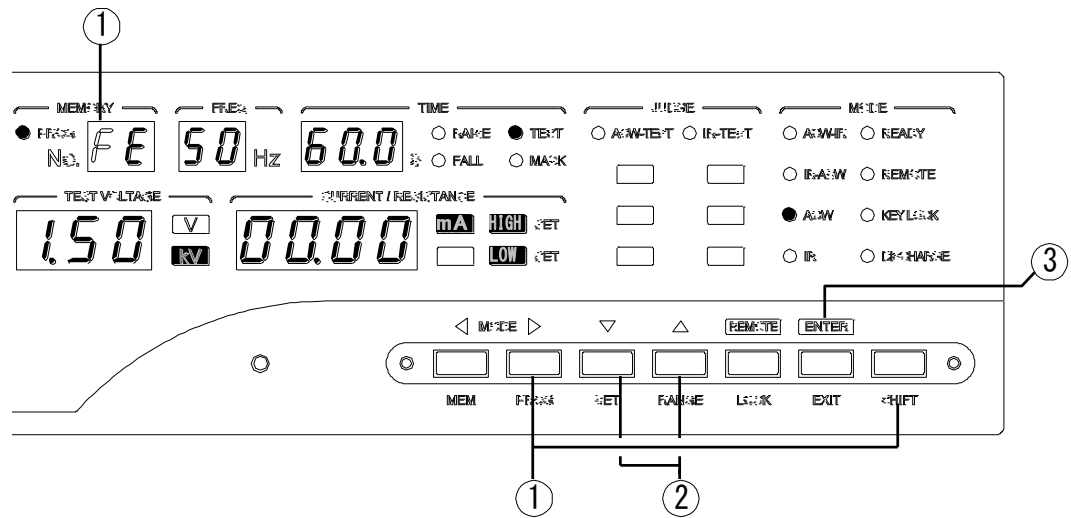

Program No. is being called.



Enter in the program

- ① Press the PROG (Hold down the SHIFT and PROG) in the READY state.
  - PROG lamp is turned on in MEMORY display and blinks program no.



Selection of program numbers

- ② Selection is done using  and  keys. 16 units of 0~F

End of the call of program operation

- ③ Press the program key and the program test returns to the READY state.

Returns to READY state of panel setting mode from program operation

- During the READY state of program test, if  and  keys are pressed it returns to the state it was before entering the program mode. Test MODE (MODE) lamp blinks at this time.
- When ENTER key is pressed, it returns to the READY state of the panel setting mode.

# Setting of the program

Setting is done for each program number and for each step number.

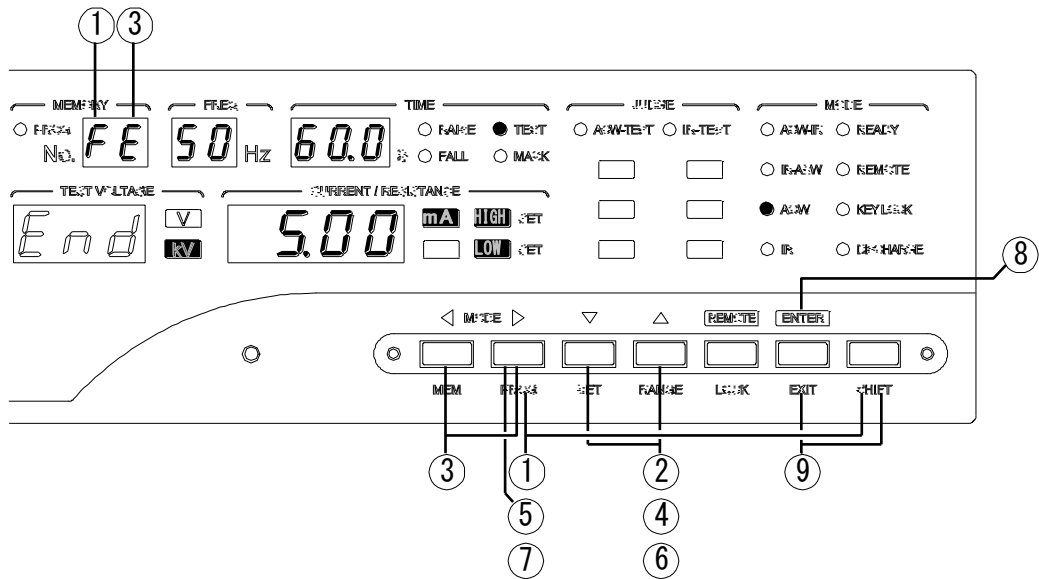

Enter in the program

- ① Press the PROG key (Hold down the SHIFT and PROG) in the READY state.

• Program lamp is turned on in MEMORY display and program number is displayed by blinking.

Selection of program No.

- ② Number is selected using  and  keys. 16 units of 0~F

Selection of step No.

- ③ The digit of step number blinks using  key.

- ④ Select the number using  and  keys. 16 units of 0~F

Setting of the test conditions of step

- ⑤ Enter in the setting of test conditions using  key.

By pressing the  key, it switches to the following content.

Test voltage setting

- ⑥ Setting of the test voltage of step is done using  and  keys. (0.00~5.50kV)

Depending on the test voltage of previous step, the rise, fall and maintaining of the test voltage is performed.

Example) Set 5.00kV when the voltage of previous step is 2.00 kV

→Test voltage gradually increase till 2.00~5.00kV

Example) Set 0.00 kV when the test voltage of previous step is 2.00 kV

→Test voltage gradually fall till 2.00~0.00kV

Example) Set 2.00 kV when the test voltage of previous step is 2.00 kV

→Maintain next step till 2.00kV

- ⑦ Press  key.

Upper limit judgment value setting

- ⑧ Sets the leakage current upper limit judgment value of the step using  and  keys. (0.01~20.00mA)

Lower limit judgment value setting

- ⑨ Sets the leakage current lower limit judgment value of the step using  and keys .

※In case the test voltage is on rise or fall, lower limit judgment value is not performed.

Test time setting

- ⑩ Sets the test time of the step using ▲ and ▼ keys.  
(0.1~99.9/100~999 seconds)

Test voltage frequency setting (step 0 only)

- ⑪ Sets the test voltage of the frequency using ▲ and ▼ keys.  
Step 0 is only possible and the remaining steps follow this setting.

Next step switching over setting

- ⑫ Sets the presence and absence of the switching over of next step using ▲ and ▼ keys.  
(ON: Switching over, END: End without switching over)  
※Step F only for END fixed.  
(Later returns to the test voltage setting.)

End of the test conditions setting of the step

- ⑬ Returns to READY state if ENTER key is pressed.

Interruption of step conditions of program operation

- ⑭ When EXIT key (EXIT holding down SHIFT) is pressed, the content edited is discarded and returns to the state just before entering test conditions setting of the step.

Return from program operation to READY state of the panel setting mode

- ⑮ In the READY state of program operation, if ◀ and ▶ keys are pressed, it enters in the test conditions setting of the panel setting mode.

• Returns to READY state of panel setting mode if ENTER key is pressed.

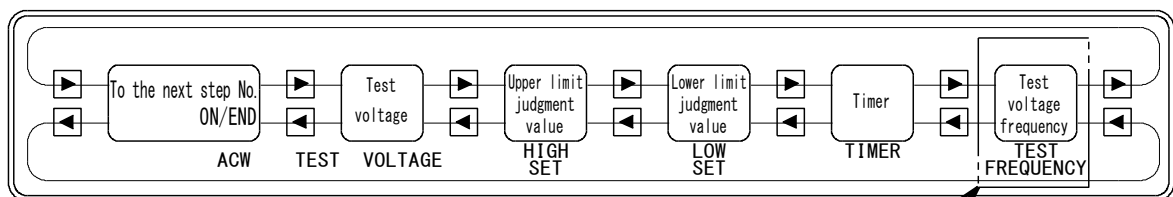

50/60Hz is set during STEP 0.

**Caution**

To perform test conditions setting of another step, once complete or cancel the setting and reselect the step No.

---

---

## 9. Test method (From the start of the test till the judgment)

---

---

Method operation of single withstand voltage test.....	48
Operation method of single insulation resistance test .....	49
Operation method of automatic test.....	50
Operation method of program operation test .....	51

## Method operation of single withstand voltage test

### Test start~Test end

- ① When START switch is pressed, DANGER lamp is turned on and the test starts.
- ② ACW-TEST lamp turns on during high voltage output.
- ③ During the test, TEST/H.V.OUT output and ACW-TEST output is turned on using remote I/O connector.
- ④ When the test is ended, TEST/H.V.OUT output and ACW-TEST output is turned off, judgment result and END output is turned on.

### Interruption of the test

When STOP switch is pressed during the test, the test is interrupted.  
It returns to the READY state.

### Judgment result

When the judgment is GOOD

When the test time has elapsed, the test is ended and the judgment is GOOD and GOOD, ACW GOOD and END are turned on.

When the judgment is NG

During the test, in case of NG judgment of the upper limit value and the lower limit value, the test is interrupted and high voltage output is turned off. Judgment result and END are the output.

### Lamp lighting condition of ACW test time

Types of lamp	READY	During RAISE	During test	During FALL	During judgment
DANGER	—	●	●	●	—
PROG	—	—	—	—	—
V , kV	●	●	●	●	●
mA, MΩ	●	●	●	●	●
HIGH SET	●	●	●	●	●
LOW SET	● (Lower limit judgment setting time)	● (Lower limit judgment setting time)	● (Lower limit judgment setting time)	● (Lower limit judgment setting time)	● (Lower limit judgment setting time)
RAISE	—	●	—	—	● (Test end time in case of RAISE)
TEST	●	—	●	—	● (Test end time in case of TEST)
FALL	—	—	—	●	● (Test end time in case of FALL)
MASK	—	—	—	—	—
ACW-TEST	—	●	●	●	—
IR-TEST	—	—	—	—	—
GOOD	—	—	—	—	● (GOOD time)
HIGH	—	—	—	—	● (Upper limit judgment time)
LOW	—	—	—	—	● (Lower limit judgment time)
ACW-IR	—	—	—	—	—
I-ACW	—	—	—	—	—
ACW	●	●	●	●	●
IR	—	—	—	—	—
READY	●	—	—	—	—
DISCHARGE	—	—	—	—	—

# Operation method of single insulation resistance test

## Test start~Test end

- ① When START switch is pressed, DANGER lamp is turned on and the test starts.
- ② IR-TEST lamp turns on during high voltage output.
- ③ During the test, TEST/H.V.OUT output and IR-TEST output is turned on using remote I/O connector.
- ④ When the test is ended, TEST/H.V.OUT output and IR-TEST output is turned off, judgment result and END output is turned on.

## Interruption of the test

When STOP switch is pressed during the test, the test is interrupted.  
It returns to the READY state.

## Judgment result

When the judgment is GOOD

When the test time has elapsed, the test is ended and the judgment is GOOD and GOOD, IR GOOD output and END are turned on.

When the judgment is NG

During the test, in case of NG judgment of upper limit value and the lower limit value, the test is interrupted and high voltage output is turned off. Judgment result and END are the output.

## Lamp lighting condition of IR test time

Types of lamp	READY	During MASK	During test	During discharge	Judgment time
DANGER	—	●	●	●	—
PROG	—	—	—	—	—
V、kV	●	●	●	●	●
mA、MΩ	●	●	●	●	●
HIGH SET	● (Upper limit judgment value setting time)	● (Upper limit judgment value setting time)	● (Upper limit judgment value setting time)	● (Upper limit judgment value setting time)	● (Upper limit judgment value setting time)
LOW SET	●	●	●	●	●
RAISE	—	—	—	—	—
TEST	●	●	●	●	●
FALL	—	—	—	—	—
MASK	—	●	—	—	—
ACW-TEST	—	—	—	—	—
IR-TEST	—	●	●	●	—
GOOD	—	—	—	—	● (GOOD time)
HIGH	—	—	—	—	● (Upper limit setting time)
LOW	—	—	—	—	● (Lower limit setting time)
ACW-IR	—	—	—	—	—
IR-ACW	—	—	—	—	—
ACW	—	—	—	—	—
IR	●	●	●	●	●
READY	●	—	—	—	—
DISCHARGE	●	—	—	◎	—

## Operation method of automatic test

---

### Test start~Test end

- ① When START switch is pressed, DANGER lamp is turned on and the test starts.
- ② Depending on test order, ACW-TEST lamp or IR-TEST is turned on during high voltage output.
- ③ During the test, TEST/H.V.OUT output, ACW-TEST output and IR-TEST output are turned on and END output is turned off using remote I/O connector. However, ACW-TEST output and IR-TEST output are switched over depending on the test order.
- ④ When the test is ended, TEST/H.V.OUT output, ACW-TEST output and IR-TEST output are turned off, judgment result and END output is turned on.

### Interruption of the test

When STOP switch is pressed during the test, the test is interrupted.  
It returns to the READY state.

### Judgment result

When the judgment is GOOD

When the test time is elapsed, the test is ended and the GOOD judgment is performed and GOOD, ACW GOOD output, IR GOOD and END are turned on.

When the judgment is NG

During the test, in case of NG judgment of upper limit value and the lower limit value, the test is interrupted and high voltage output is turned off. Judgment result and END are the output.

Lamp lighting condition is the combination of the lamp lighting condition of ACW test mode time and IR test mode time.



## Operation method of program operation test

### Test start~Test end

- ① When START switch is pressed, DANGER lamp is turned on and the test starts.
- ② Depending on test order, ACW-TEST lamp is turned on during high voltage output.
- ③ During the test, TEST/H.V.OUT output and ACW-TEST output are turned on and END output is turned off using remote I/O connector.
- ④ When the test is ended, TEST/H.V.OUT output and ACW-TEST output are turned off, judgment result and END output is turned on.

### Interruption of the test

When STOP switch is pressed during the test, the test is interrupted.  
It returns to the READY state.

### Judgment result

When the judgment is GOOD

When the test is elapsed, the test is ended and the GOOD judgment is performed and GOOD, ACW GOOD output and END are turned on.

When the judgment is NG

During the test, in case of NG judgment of upper limit value and lower limit value, the test is interrupted and high voltage output is turned off. Judgment result and END are the output.

### Lamp lighting condition of program operation test time

Types of lamp	READY	During test	Judgment time
DANGER	—	●	—
PROG	●	●	●
V、kV	●	●	●
mA、MΩ	● (Display of upper limit judgment value)	● (Measurement display)	● (Display of measurement value when the test ends)
HIGH SET	●	●	●
LOW SET	● (Lower limit judgment value setting time)	● (Lower limit value setting time)	● (Lower limit value setting time)
RAISE	—	● (When setting voltage is higher than the previous step)	● (When RAISE during end of the test)
TEST	●	● (When setting voltage is equal to the previous step)	● (When TEST during end of the test)
FALL	—	● (When setting voltage is lower than the previous step)	● (When FALL during end of the test)
MASK	—	—	—
ACW-TEST	—	●	—
IR-TEST	—	—	—
GOOD	—	—	● (GOOD time)
HIGH	—	—	● (upper judgment time)
LOW	—	—	● (Lower judgment time)
ACW-IR	—	—	—
IR-ACW	—	—	—
ACW	●	●	●
IR	—	—	—
READY	●	—	—
DISCHARGE	—	—	—

This page is blank.

---

---

## 10. Other functions

---

---

Double action start.....	54
GOOD hold .....	54
Momentary start.....	54
FAIL mode.....	54
NG start .....	54
Setting method.....	55
Setting of the buzzer .....	56
Interlock.....	57

## Double action start

After STOP input is off, START input is enabled for 0.5 second.

Item	Setting no. of ②	Default value
Setting done	1	
Setting not done	0	○

## GOOD hold

Three conditions can be selected for holding time of GOOD judgment condition

Item	Setting no. of ②	Default value
Judgment after 0.2seconds output returns to READY state	0	
Hold the judgment, after stop signal output, re-start is possible with start signal	1	
Hold the judgment, without stop signal, re-start is possible with start signal	2	○

## Momentary start

Test is done only when the START switch is hold and pressed.

Item	Setting no. of ③	Default value
Setting done	1	
Setting not done	0	○

## FAIL mode

The release of NG, PROTECTION is limited to the main STOP switch.

Item	Setting no. of ②	Default value
Setting done	1	
Setting not done	0	○

## NG start

Following the NG decision, the condition to start the test is set.

ON : Even if NG judgment is not released by STOP, the test is started by START.

OFF : NG judgment is released by STOP and test is started by START.

Item	Setting no. of ②	Default value
OFF	0	
ON	1	○

# Setting method

Setting item	Selectable LED
Double action start	(a)
GOOD hold	(b)
Momentary start	(c)
FAIL mode	(d)
NG start	(e)

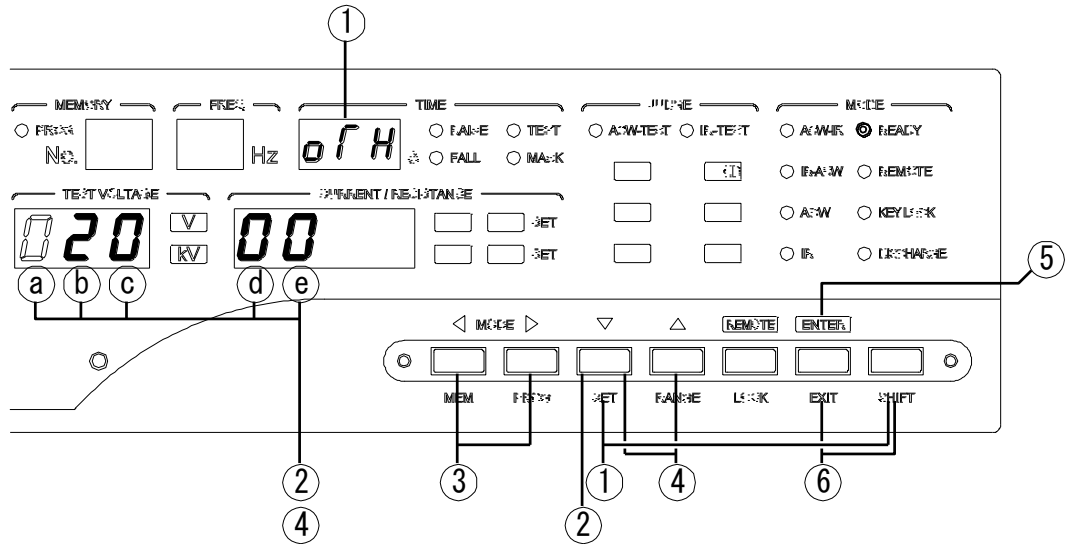

Enter in the other settings

- ① Press SET key (Hold down SHIFT and SET) for 3 seconds in the READY state.
- Time display will blink “07H”.

Enter in the setting item

- ② Enter in the setting item using  key.
- TEST VOLTAGE display part (a) blinks and setting condition in CURRENT/RESISTANCE display is turned on.

Selection of setting item

- ③ One of (a), (b), (c), (d), (e) is selected using  and  keys. Selected item blinks.

Setting

- ④ Setting no. is set by using  and  keys.
- Refer the contents of the previous page.

End of the setting

- ⑤ When ENTER key is pressed, the setting is stored and returns to READY state.

Interruption of the setting

- ⑥ When EXIT key (Hold down SHIFT and EXIT) is pressed, the setting is interrupted and returns to READY state. The setting content at that time will be the state it was before entering the setting.

## Setting of the buzzer

Buzzer rings when the judgment passes or fails.

The on/off setting of the buzzer is possible using setting of the front panel.

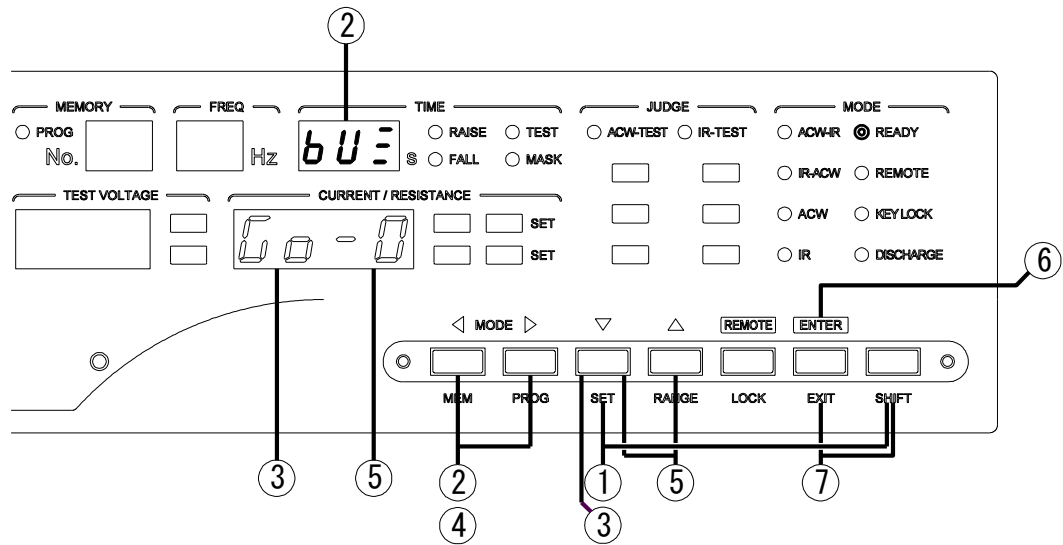

Enter in the setting

- ① Press SET key (Hold down SHIFT and SET) for 3 seconds in the READY state.
- TIME display will blink “ofH”

- ② “bu” is selected using key.

- ③ Enter in the setting using key.
- Setting state blinks in CURRENT/RESISTANCE display.

Selection of GOOD buzzer

- ④ Select “00-0” (Pass buzzer off) using key.
- ⑤ “00-1” (Pass buzzer on) using key and “00-0” (pass buzzer off) using key.
- Setting state blinks in CURRENT/RESISTANCE display.

Selection of NG buzzer

- ⑥ Select “n0-0” (Fail buzzer off) using key.
- ⑦ “n0-1” (Fail buzzer on) using key and “n0-0” (Fail buzzer off) using key.
- Setting state blinks in the CURRENT/RESISTANCE display.

Confirmation of the buzzer

The confirmation of the on/off setting is possible depending on the pressing of STOP switch.

Setting range		Buzzer sound
For pass judgment	For fail judgment	
00-1	n0-1	On
00-0	n0-0	Off

Depending on and keys, it returns to the selection of ④ ⑤GOOD and NG buzzer.

End of the setting

- ⑧ When ENTER key is pressed, setting is memorized and returns to the READY state.

Interruption of the setting

- ⑨ When EXIT key is pressed (EXIT holding SHIFT), the setting is interrupted and returns to READY state. The setting content at that time will be the state it was before entering the setting.

# Interlock

Sets to enable and disable the interlock signal of remote I/O connector.

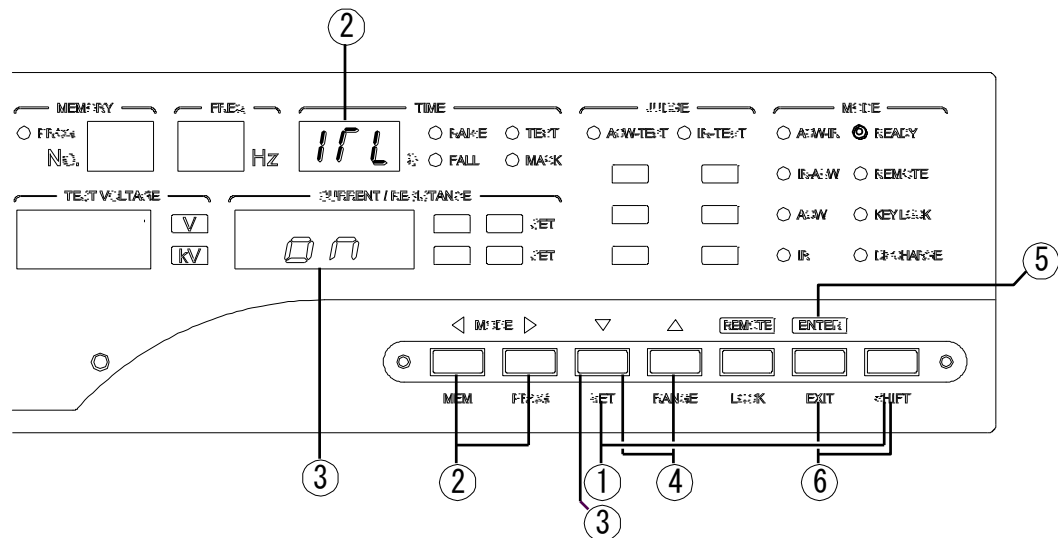

## Enter in the setting

- ① Press SET key (Hold down SHIFT and SET) for 3 seconds in READY state.  
• "o f H" blinks in the TIME display.
- ② Select "1 f L" using key.
- ③ Enter the setting using key.  
• Setting state blinks in the CURRENT/RESISTANCE display.

## Setting

- ④ Select enable "o n" and disable "o f f" using and keys.  
• Setting state blinks in the CURRENT/RESISTANCE display.

## End of the setting

- ⑤ When ENTER key is pressed, the setting is memorized and returns to READY state.

## Interruption of the setting

- ⑥ When EXIT key (EXIT holding SHIFT) is pressed, the setting is interrupted and returns to the READY state.  
The setting content at that time will be the state it was before entering the setting.

This page is blank.



---

---

## 11. Remote I/O

---

---

Test contents depending on remote I/O.....	60
Connector pin array and pin function .....	61
Call Memory No. from remote I/O .....	62
Combination of Memory No. and MEM SET Signals .....	63
I/O control by MEM SET .....	64
I/O control by REAR MODE .....	65
I/O Control with combination of REAR MODE and MEM SET .....	67
I/O Control with separate judgment (During GOOD judgment) .....	68
I/O Control with separate judgment (During ACW-NG Upper limit judgment) .....	69
I/O Control with separate judgment (During IR-NG lower limit judgment) .....	70
Timing Chart: Details from the start to the high voltage output.....	71
Interlock signal .....	72
Protective function operation (PROTECTION) .....	72
Input signal .....	73
Output signal and the control power supply .....	74



# Connector pin array and pin function

	+24V	1	DC24V Outputs control power supply (capacity 0.1A)
—	NC	2	Free pin (Do not hook up etc. for wiring)
I	START	3	Start input signal
	STOP	4	Stop input signal
	INTERLOCK	5	Interlock signal
	MEM SET1	6	Memory No.calling input signal can be selected from memory No. 1 to 16 by the combination of pin No. 6,7,8,9 and 27.
	MEM SET2	7	
	MEM SET4	8	Refer to “Combination of Memory No. and MEM SET signals”. (Refer after 2 page)
	MEM SET8	9	
O	TEST/H.V.OUT	10	Outputs High voltage terminal during voltage output time
	READY	11	Outputs during READY state time
	PROTECTION	12	Outputs during protective function operation time
	GOOD	13	Outputs during pass judgment time
	ACW HIGH	14	Outputs during upper limit judgment time of withstand voltage test
	ACW GOOD	15	Outputs during pass judgment time of withstand voltage test
	IR HIGH	16	Outputs during upper limit judgment time of insulation resistance test.
	IR GOOD	17	Outputs pass judgment time of insulation resistance test.
—	NC	18	Free pin (Do not hook up etc. for wiring)
COM	COM	19	Common (Common with No.23 and36)
I	REAR MODE	20	Becomes a test mode switching operation (ACW, IR) from rear panel.
	ACW-MODE	21	Mode setting of withstand voltage (REAR: Valid at the time of MODE setting)
	IR-MODE	22	Mode setting of insulation resistance test (REAR: Valid at the time of MODE setting)
COM	COM	23	Common (Common with No. 19 and 36)
O	ACW-TEST	24	Outputs during test of withstand voltage test. Does not output when ACW-TEST blinks.
	IR-TEST	25	Outputs during test of insulation resistance test Does not output when IR-TEST blinks
	TEST	26	Outputs during the test Does not output when ACW-TEST and IR-TEST blinks.
I	MEM SET10	27	Memory call (memory No.16)
O	END	28	Output during test end
—	NC	29	Free pin (Do not hook up etc. for wiring)
—	NC	30	Free pin (Do not hook up etc. for wiring)
O	NG	31	Output during fail judgment time
	ACW LOW	32	Output during low limit judgment time of withstand voltage test
—	NC	33	Free pin (Do not hook up etc. for wiring)
O	IR LOW	34	Output during lower limit judgment time of insulation resistance test
—	NC	35	Free pin (Do not hook up etc. for wiring)
COM	COM	36	Common (Common with No.19 and23)

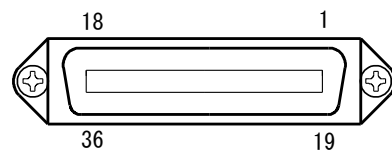
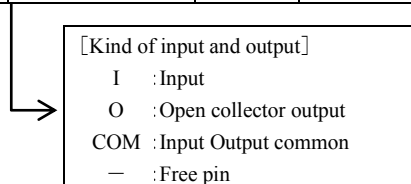

Connector used : 36P Amphenol

## Call Memory No. from remote I/O

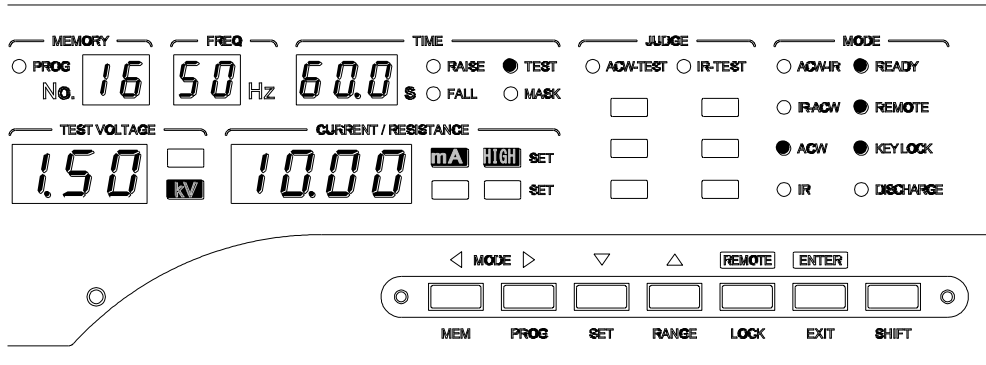

Method to call Memory No.

1. Press REMOTE key at Ready condition  
 REMOTE lamp is lit up.  
 Start cannot be done from the Panel  
 Stop key can be used from the front panel.

Select Memory No.

2. Address setting can be done from the ON/OFF signals of remote I/O of MEM SET 1,2,4,8,10.

Start test

3. Test start can be done when START of remote I/O is turned ON by non voltage contact.

### **Caution**

It does not start the test from the START signal of remote I/O connector in case there is a setting to start from START command of RS-232C/USB interface. Change the settings. See below for the reference.

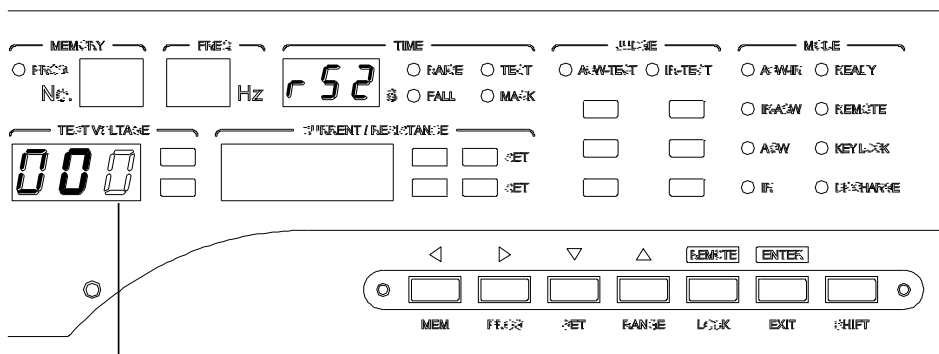

The setting value is made 0 as shown in above figure.

	Setting item	Setting no.	Default value
START	Start of the test from front panel or remote out	0	○
	Start of the test by START command (at REMOTE state)	1	—

Setting value is made 0 as in the diagram.

Refer to the separate manual [RS-232C·USB interface] for operation method.

## Combination of Memory No. and MEM SET Signals

— : Input OFF

○ : Input ON

Memory No.	PIN No.27	PIN No. 9	PIN No. 8	PIN No.7	PIN No.6
	MEM SET10	MEM SET8	MEM SET4	MEM SET2	MEM SET1
Blank ※	—	—	—	—	—
1	—	—	—	—	○
2	—	—	—	○	—
3	—	—	—	○	○
4	—	—	○	—	—
5	—	—	○	—	○
6	—	—	○	○	—
7	—	—	○	○	○
8	—	○	—	—	—
9	—	○	—	—	○
10	—	○	—	○	—
11	—	○	—	○	○
12	—	○	○	—	—
13	—	○	○	—	○
14	—	○	○	○	—
15	—	○	○	○	○
16	○	—	—	—	—
	○	—	—	—	○
	○	—	—	○	—
	○	—	—	○	○
	○	—	○	—	—
	○	—	○	—	○
	○	—	○	○	—
	○	—	○	○	○
	○	○	—	—	—
	○	○	—	—	○
	○	○	—	○	—
	○	○	—	○	○
	○	○	○	—	—
○	○	○	○	○	

※ : When memory No. display is blank, from panel becomes in setting mode.

# I/O control by MEM SET

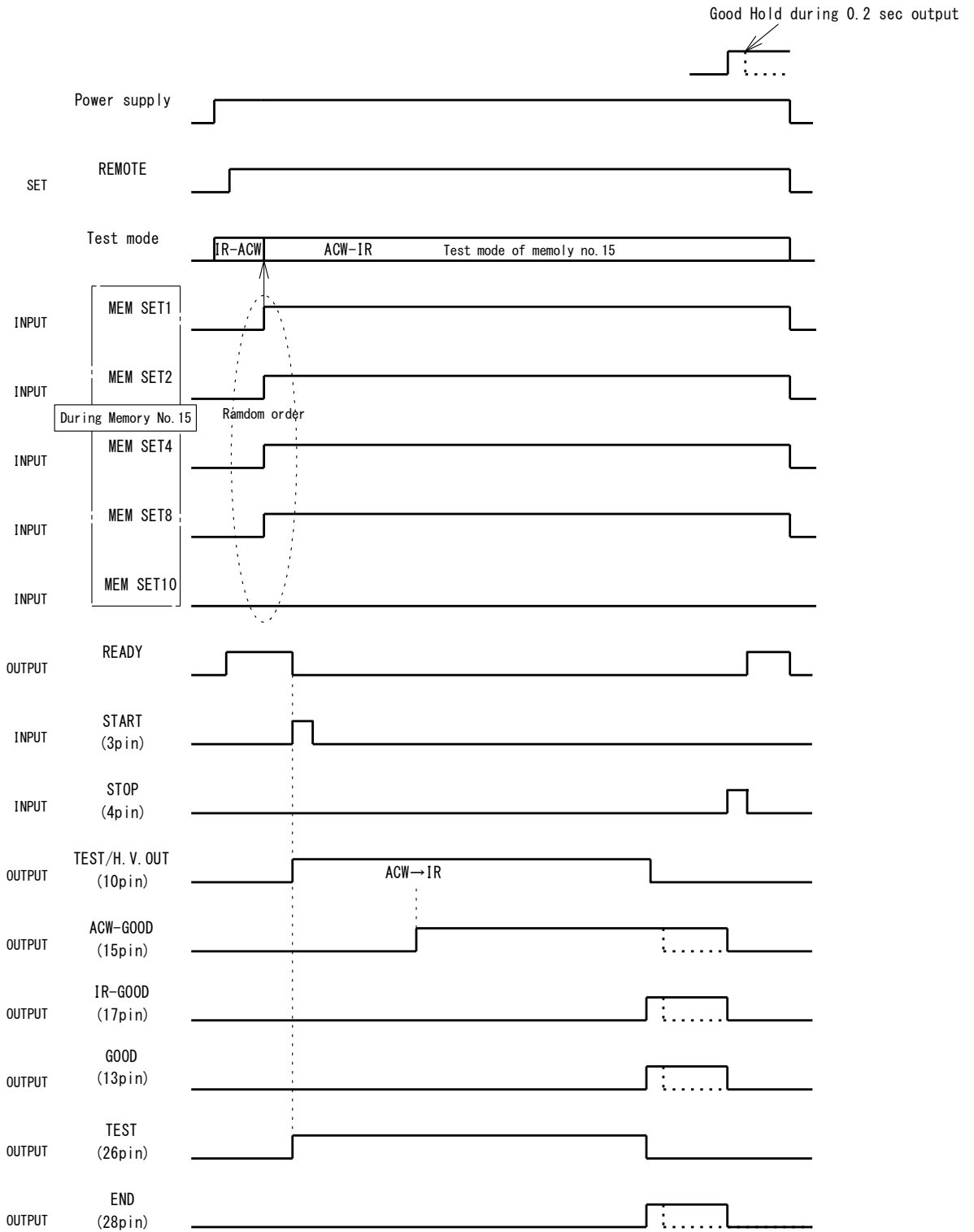

# I/O control by REAR MODE

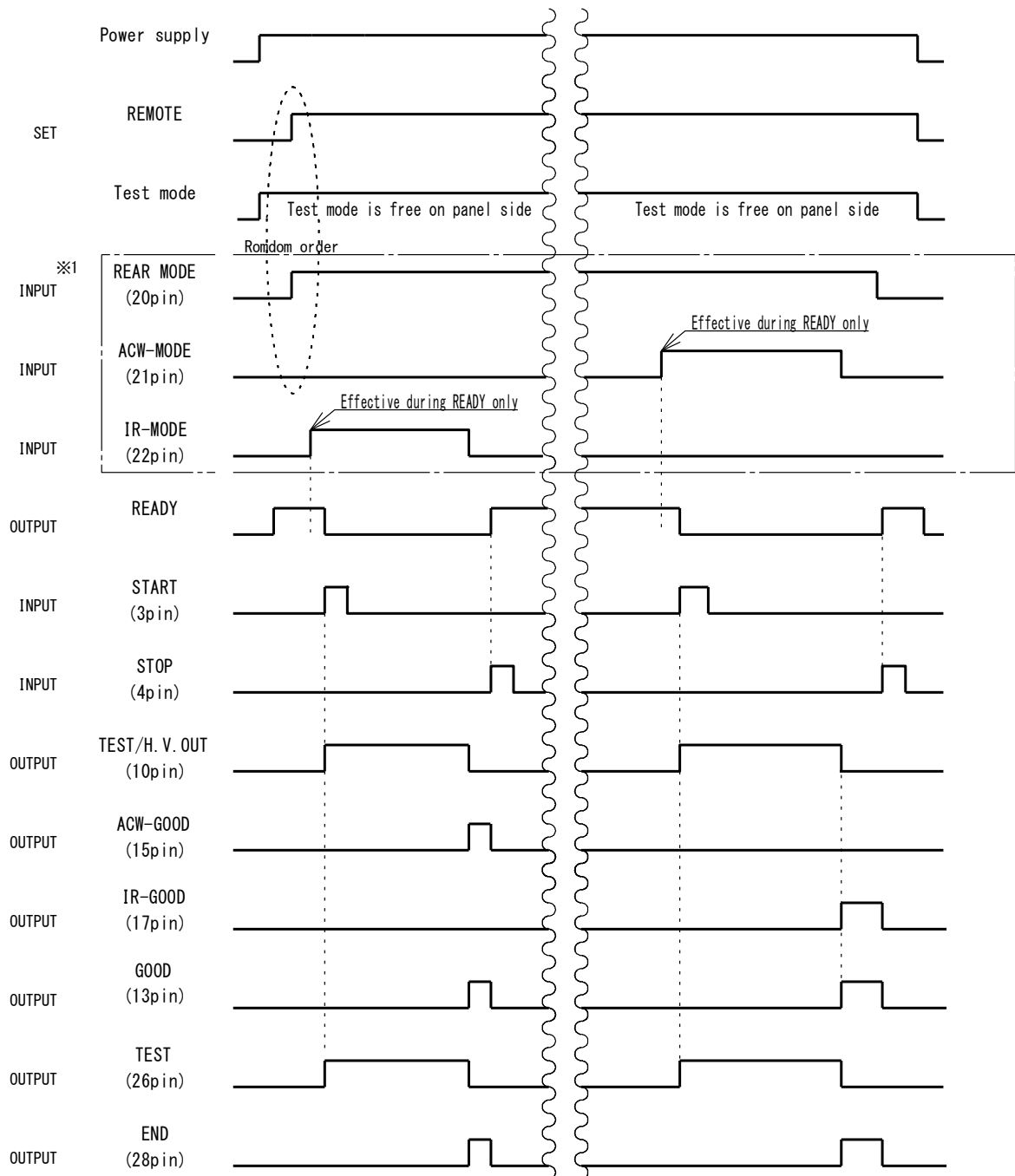

※1 : When REAR MODE is ON, individual test of ACW TEST (20 pin) and IR TEST (25 pin) can be selected. Either one ACW-TEST or IR-TEST can be selected from test mode during single test in test mode of panel display.

Setting of the test conditions for ACW, IR test contents can be memorized on front panel test mode using memory no. from 1 to 16. Refer to next page



**Caution** during the combination of ACW TEST and IR TEST when REAR MODE is used

1. Before using REAR MODE

To set the test condition, either one test condition with no memory call and memory call (16 set) would be on panel setting.

Table11.1 Setting example



Display of MEMORY No.	Setting value memorization items		
	Test mode	Test condition	
		ACW	IR
Blank (Panel setting)	ACW-IR	Display	Display
1	ACW	Display	No display
2	IR	No display	Display
1 4	IR	No display	Display
1 5	ACW	Display	No display
1 6	IR-ACW	Display	Display

2. Test content that can be carried out depending on test mode

Test contents that can be carried out which do not have difference depending on the panel setting with no memory call or with memory call (16 set).

When READY lamp is OFF during the judgment, input pin becomes invalid.  
Countermeasure: In the READY state, re-enter the test mode input pin.

Table11.2 Test which can be executed by REAR MODE

ON/OFF of test mode input pin		Test mode			
ACW-MODE (21pin)	IR-MODE (22pin)	ACW-IR	IR-ACW	ACW	IR
OFF	OFF	ACW-IR Automatic test	IR-ACW Automatic test	only ACW	only IR
ON	OFF	only ACW	only ACW	only ACW	only ACW
OFF	ON	only IR	only IR	only IR	only IR
ON	ON	ACW-IR Automatic test	IR-ACW Automatic test	only ACW	only IR



- As shown in table 11.1, the setting value of memorization items for each set of test mode are ACW test condition and IR test condition.
- During the individual test mode, memory zone of test condition toward nondisplay exists. Refer shaded test condition and test mode on table 11.1 and 11.2.
- Note that implementation of test is possible even during test condition toward non display side. After purchase when no specific setting is done, setting value on non display side will be shipment setting values. If setting is done even one time, the last setting will be momorized as the lattest test condition



# I/O Control with combination of REAR MODE and MEM SET

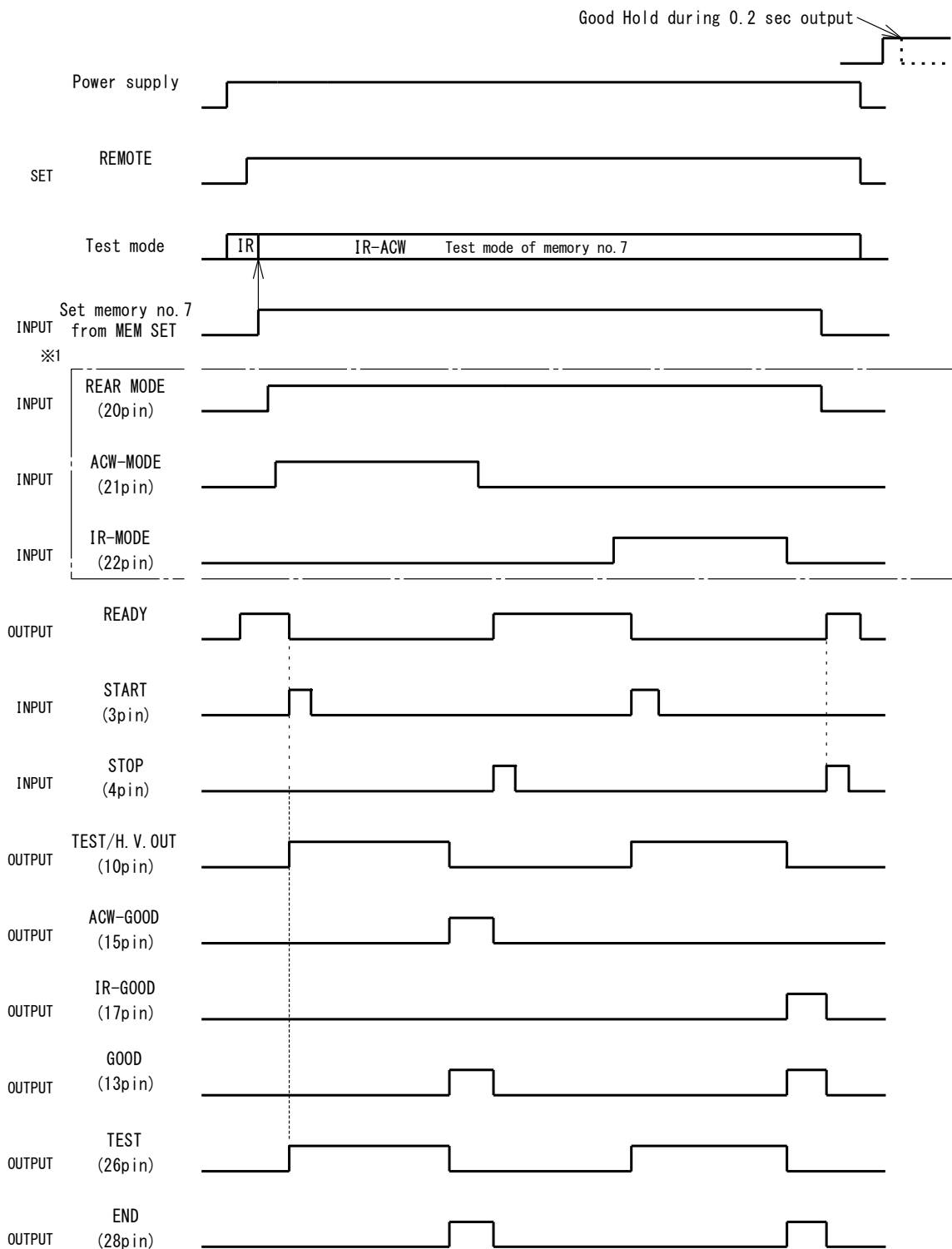

## I/O Control with separate judgment (During GOOD judgment)

Setting of MEM SET and REAR MODE are affected on the result of judgment timing and the detail explanation is omitted. Automatic test of ACW-IR is described here.

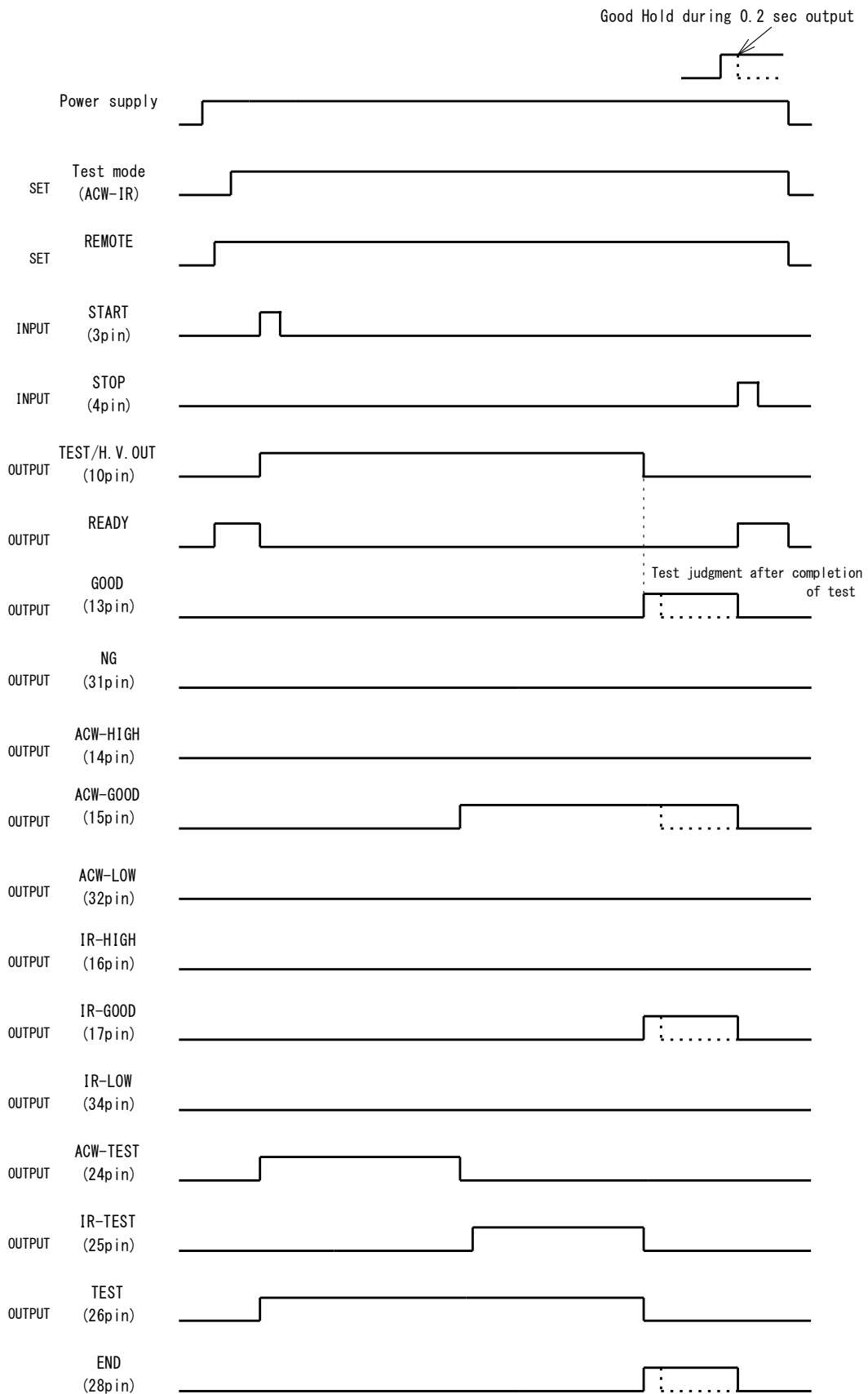

# I/O Control with separate judgment (During ACW-NG Upper limit judgment)

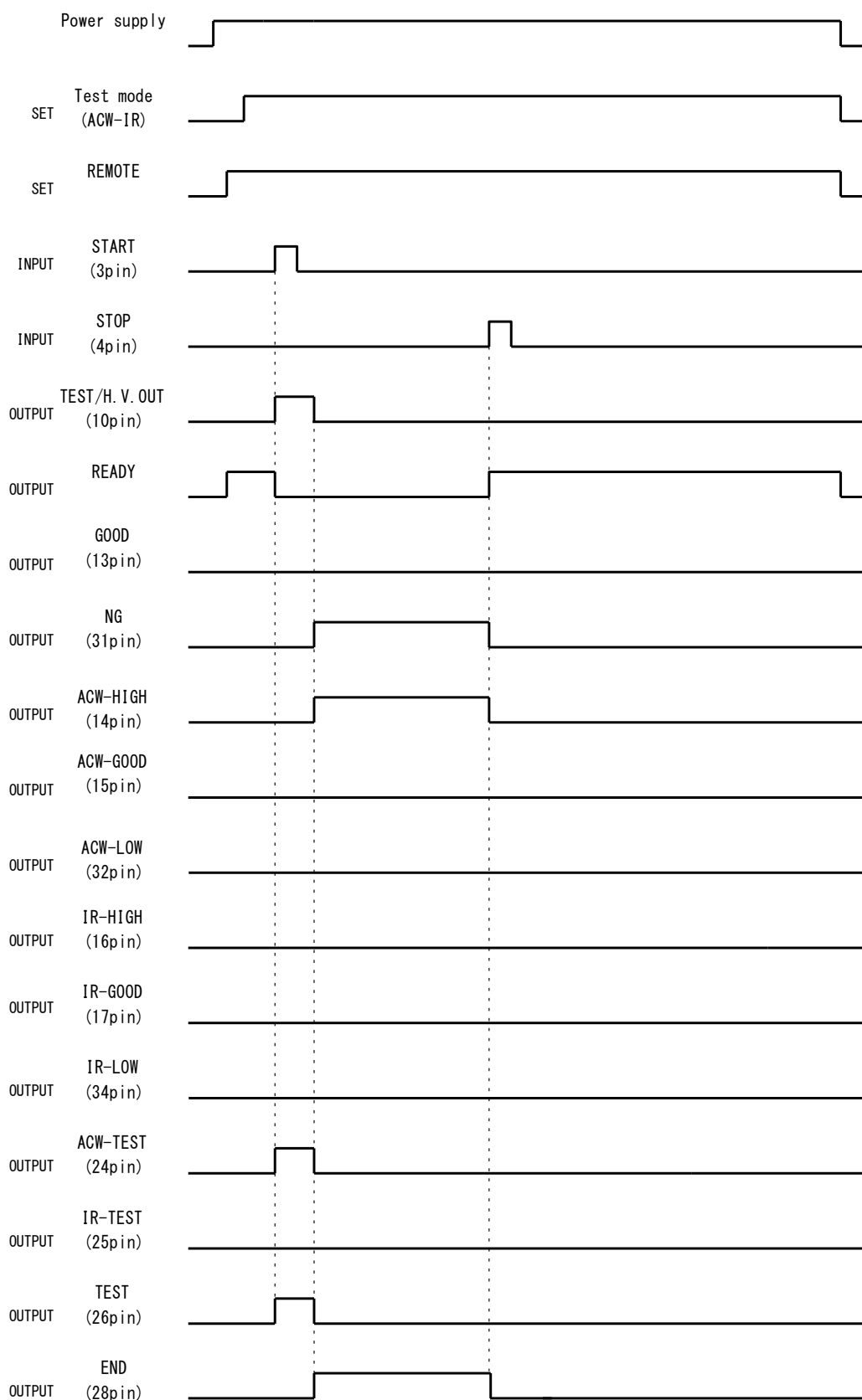

## I/O Control with separate judgment (During IR-NG lower limit judgment)

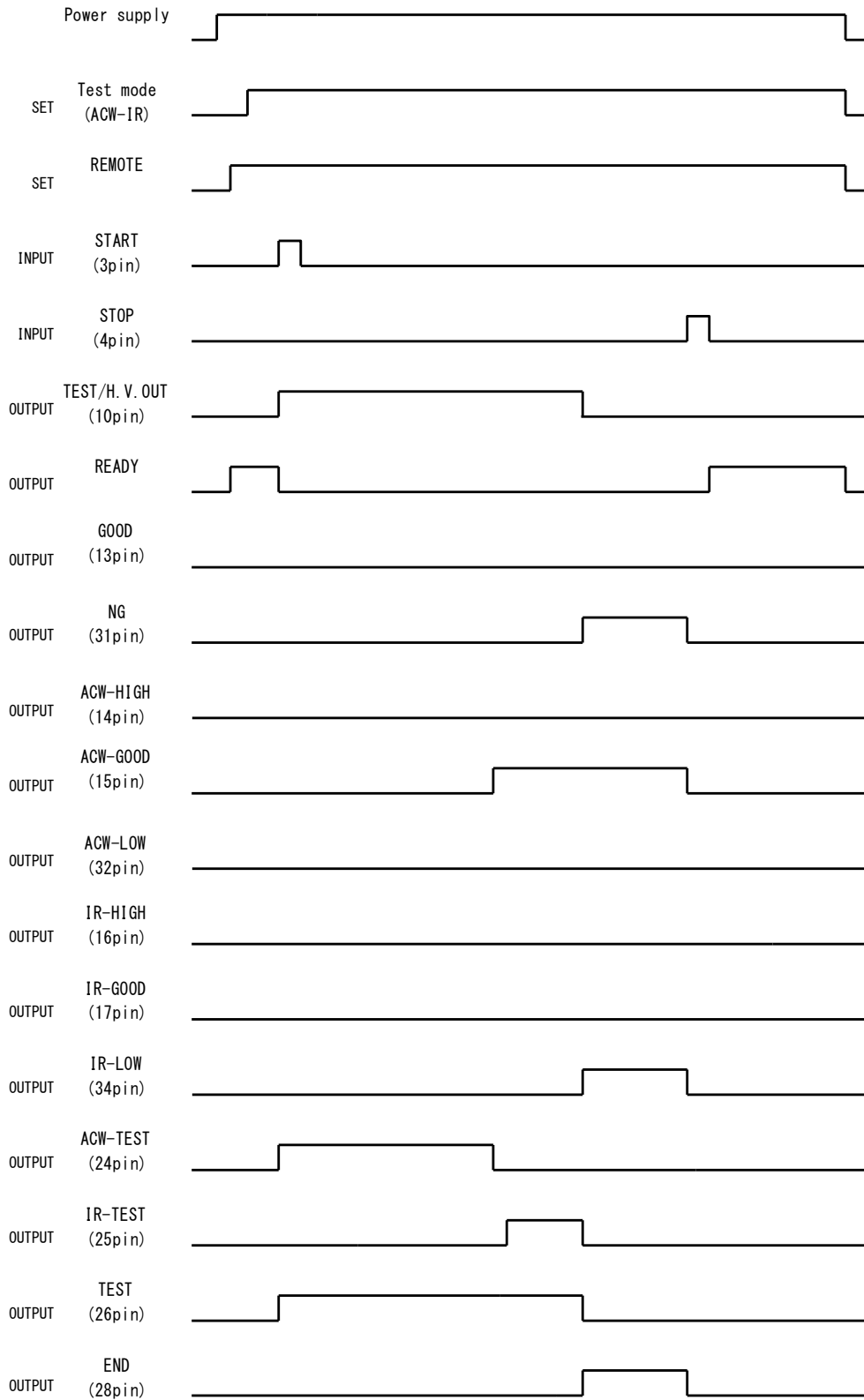

# Timing Chart: Details from the start to the high voltage output

## <ACW-GOOD>

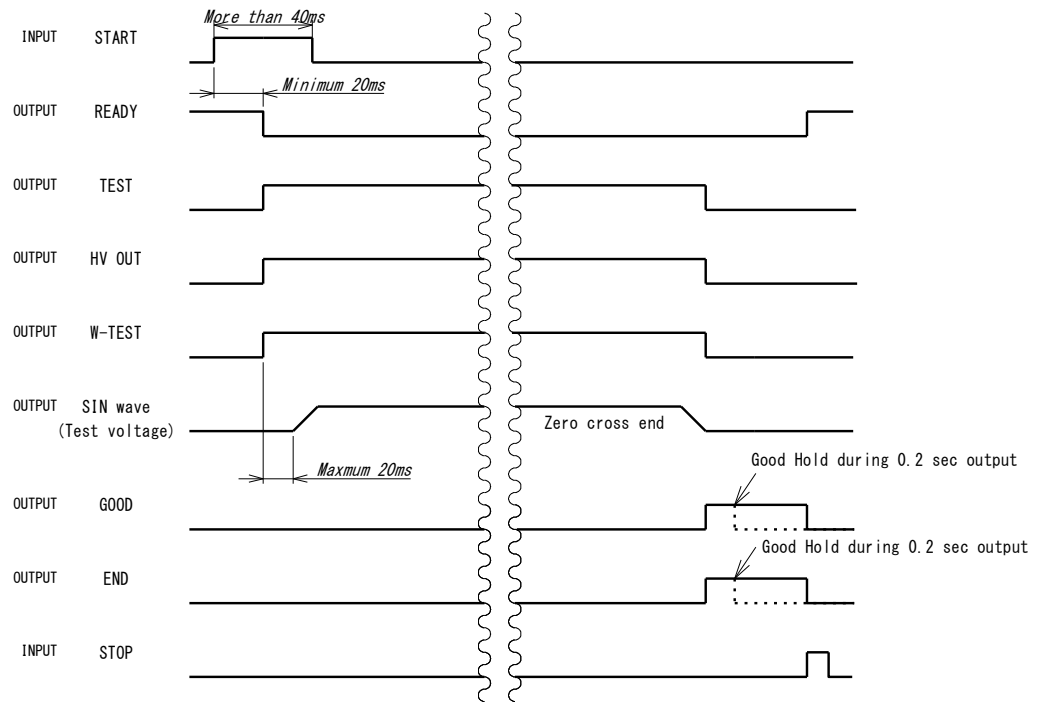

## <IR-GOOD>

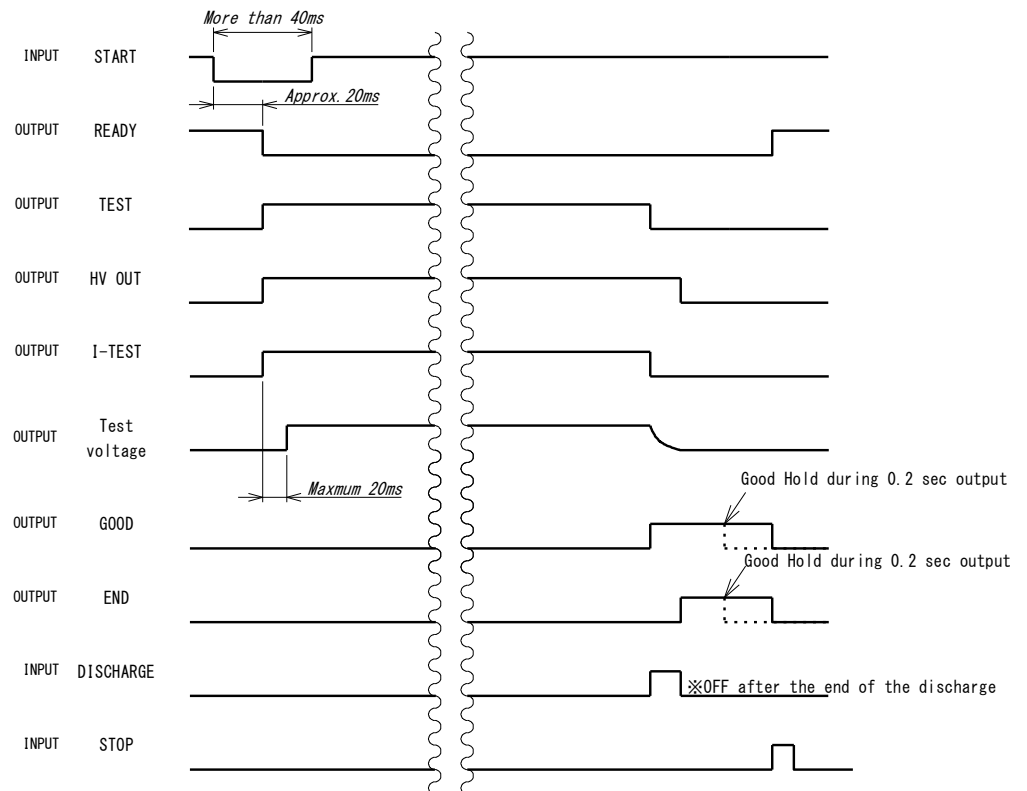

## Interlock signal

Interlock is a function to shut off the output by linking with an external device for ensuring the safety of the workers.

There is an interlock state when INTER-LOCK of remote I/O connector is opened and start of the test is not possible.

During operation of interlock function, there is a display of *Err Lock* in test voltage indicator, output of 8505 is shut off and all the key operations are disabled.

To release the interlock, INTER-LOCK of remote I/O connector and COM is short circuited and STOP switch is pressed with “L” level.

After *Err Lock* is off and READY lamp turned on, the test is possible.

Note: The supplied remote I/O plug (36P) has short circuited INTER-LOCK and COM.

In case there is no remote I/O plug, release is possible reintroducing the power, with the help of setting operation of interlock of “10. Other functions”.

As shown in the connection diagram example given below, allow the adequate interlock processing where safety is considered like linking with an external device etc.

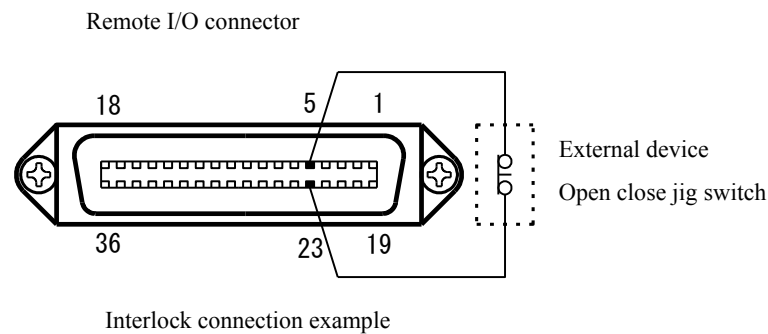

## Protective function operation (PROTECTION)

The protective function operation is an action that outputs PROTECTION due to the remote I/O connector during the undermentioned time of conditions.

- During the time when the test is ended and even when 10 seconds lapsed, the discharge of test specimen is not completed
- During the time when the test is ended and even when 10 seconds lapsed, the voltage output does not fall
- During the test when interlock input is off

Method to cope

- Refer “13. Error message”

# Input signal

Start and stop control of this tester is possible by the external input signal.  
Besides, it is possible to call the setting of the registered test conditions in the memory.

(1) Input signal specification (Pin No.2~9, 20~22, 27)

Control input: Active LOW

Input level: "H"=16.8~24V

"L"=0~3.8V

L level flow current:  $I_{ce}=10\text{mA}$

L level minimum pulse width: 40ms

Isolation Yes

(2) Internal circuit configuration

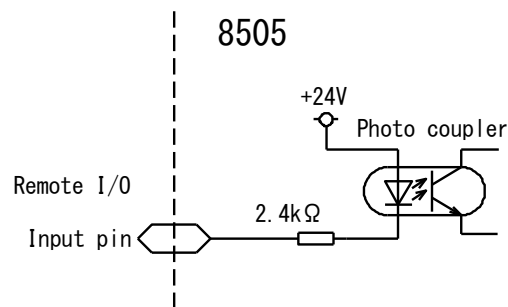

(3) Example of control using transistor

Design the collector current with maximum 10mA.

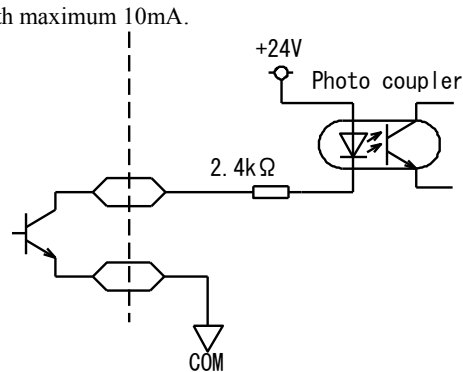

(4) Example of control using external switch

Provide the circuit to prevent relay or chattering of the switch.

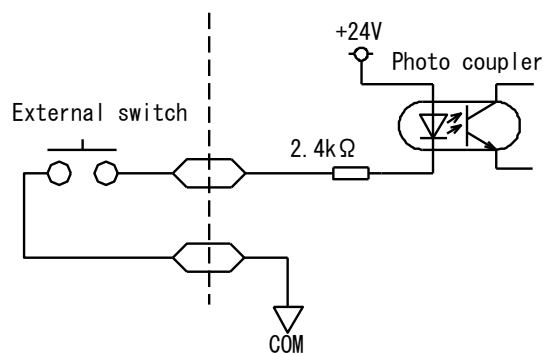

## Output signal and the control power supply

Each state of output signal of 8505 can be taken out.  
It is equipped with control power supply of DC24V.

(1) Output signal specification (Pin No.10~17, 24~26, 28, 31, 32, 34)

- Signal format: Open collector output
- Maximum load voltage: DC30V
- Maximum output current: DC30mA
- Isolation Yes
- Output saturation voltage: Less than DC1.6V

(2) Control power supply specification (Pin No. 1)

- Output voltage: DC24V
- Current capacity : DC0.1A

**⚠ Caution**

As the ampacity of 8505, +24V (1 pin) is 0.1 A, use external power supply.

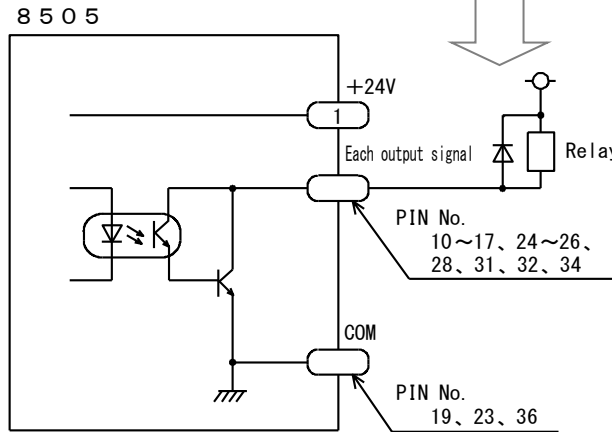

Example of relay drive connection

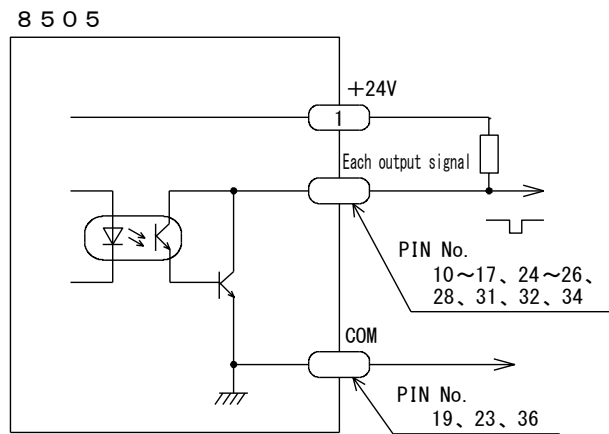

Example of getting signal level

**⚠ Caution**

- Use output signal less than DC30V 30mA.
- In case of inductive load control like relay etc., connect the coil and the diode in parallel and absorb the counter electromotive force.



---

---

## 12. PC remote control

---

---

RS-232C•USB Interface ..... 76

## **RS-232C•USB Interface**

---

Refer to the separate instruction manual I-02224.

---

---

## 13. Error message

---

---

Error display .....	78
Coping with error display .....	78

## 13. Error message

When an error occurs, depending on the situation it is displayed as shown in the table. Cope with it after confirming the error number.

Example) When interlock input is off

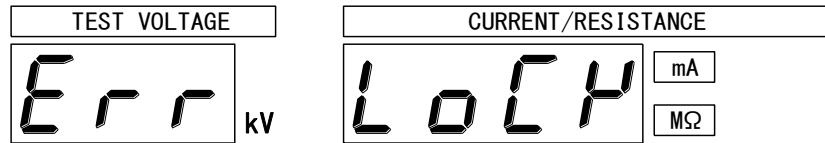

## Error display

Error display		Cause	Counter measure No.	
<i>Err</i>	<i>CHrG</i>	Even when 10 seconds elapsed, the discharge of the test specimen is not completed	D	※
<i>Err</i>	<i>LoCH</i>	When interlock input is off	B	※
<i>Err</i>	<i>E-11</i>	In momentary operation, when the start signal is turned off during withstand voltage test	C	
<i>Err</i>	<i>E-21</i>	In momentary operation, when the start signal is turned off during insulation resistance test	C	
<i>Err</i>	<i>E-30</i>	During withstand voltage test, when the internal components are in overheated state	E	※
<i>Err</i>	<i>E-31</i>	When the internal components become abnormal or breakdown	A	※

※: Outputs PROTECTION from remote I/O connector ⑤

## Coping with error display

Counter measure No.	Method to cope
A	Immediately turn OFF the power. Contact the agency or this company as there is a possibility of breakdown of this 8505 tester.
B	Interlock input is now OFF. Connect interlock input correctly by reviewing the connection or the sequence. STOP switch ⑬ is pressed and brought to READY state. (Besides, release interlock function 10. Other functions)
C	STOP switch ⑬ is pressed and brought to READY state. Review connection or sequence such that the start signal during the test is not OFF.
D	When the capacity of the test specimen is large, discharge is not possible and there is a case where high voltage remains. Leave it alone for some time and continue the discharge. When the discharge is completed, it is possible that the STOP command or error display in STOP switch is released.
E	It is possible that the internal components are in the overheated state when the test is done for a long time. Wait for a while at the power on state till the heat is dissipated. When the heat dissipation is completed, it is possible that the STOP command or error display in STOP switch is released.

---

---

# 14. Maintenance

---

---

Cleaning..... 80  
Problem solving..... 80  
Calibration..... 80

## Cleaning

In order to remove the dirt from this tester, wipe lightly by a soft cloth with small amount of water and small amount of mild neutral detergent.

Do not use detergents containing solvents like benzene, alcohol, paint thinner etc. It may cause deformation and decoloration.

## Problem solving

In order to solve the problem, check the description in “Problem solving” and contact the nearest dealer or nearest sales office.

When breakdown goods are to be returned

The goods are to be packed so that it does not get damaged during transportation and write and attach the breakdown description as well. There is no guarantee for the damage during transportation.

When you think that there is a breakdown

Conditions	Confirmation	Countermeasure
No display even when the power switch is turned on.	Check if the power cord is unplugged.	Plug in the power cord.
Cannot operate the keys.	Is it in the key lock state?	Release the key lock.
Test is not started even when START switch is pressed.	<ul style="list-style-type: none"> <li>•Is READY lamp turned on?</li> <li>•Is REMOTE lamp turned off?</li> </ul>	<ul style="list-style-type: none"> <li>•Check the settings of other functions.</li> <li>•START switch is disabled during remote control.</li> </ul> Refer to Chapter 12~Chapter 13 for remote control.
When you press START switch <i>Err LoCh</i> is blinked.	<i>Err LoCh</i> is blinked.	Release the interlock with the reference of interlock or external control interlock of other functions.
Error display	Error display	Refer to the error display.

## Calibration

For the long protection of accuracy, it is recommended to calibrate the instruments every year.

Customers are requested to contact the sale offices of Tsuruga Electric Corporation or the dealer/distributor of Tsuruga Electric Corporation for the calibration.

However, the repair and calibration may be refused if the production of the product is abolished after certain elapse of time or if the warranty range is not covered.

---

---

## 15. Specifications

---

---

Withstand voltage test.....	82
Insulation resistance test .....	84
Memory operation .....	85
Program operation .....	85
Other functions .....	86
Input Output signal .....	86
RS-232C•USB Interface .....	87
General specification .....	88
Setting of the default value .....	88
Dimensions .....	90
MEMO.....	91

## Withstand voltage test

- Test voltage
  - Applied voltage : AC 0.2~5.00kV
  - Output capacity : 100VA (5kV, 20mA) Continuous application time of the maximum current output within 30 minutes
  - Wave form : Sine wave (Rate of strain : Less than 5% No-load)
  - Power frequency : 50/60Hz (Regardless of the power frequency 50/60Hz switchable)
  - Voltage fluctuation rate : Less than 15% (Maximum rating → No-load: In resistive load)
  - Voltage application method : Zero cross switch  
After the time up and NG judgment time, cut off applied voltage
  - Applied voltage setting : Digital setting (Setting resolution 0.01kV)  
Setting accuracy  $\pm (1.5\%+20V)$  of the setting No-load
  
- Voltage measurement
  - Rectification method : Average rectified effective value display
  - Digital display : Display range 0.00~6.00kV  
Resolution 0.01kV  
Measurement accuracy  $\pm (1.5\% \text{ of rdg. } ), \text{ Less than } 500V \pm (1.5\% \text{ of rdg. } +20V)$   
Character 10mm (Green LED)  
Operation Show the applied voltage during the test  
During the end of the test, retain the display of the end time of the test.  
The value of NG judgment is not necessarily the value at the time of NG judgment from the relationship of response speed.  
Response time 100ms
  
- Current measurement
  - Rectification method : Average rectified effective value display
  - Digital display : Measurement range 0.00~20.00mA  
Resolution 0.01mA  
Measurement accuracy  $\pm (2\% \text{ of rdg. } +0.05mA)$   
Character 10mm (Green LED)  
Operation Display the leakage current during the test  
At the end of the test, retains the display of the end time of the test.  
Analog comparator operation becomes over display  
Over display  displays light  
When it exceeds 20.00mA When overcurrent like spark etc. flows, when the analog comparator is activated.  
Response time 100ms



Judgment method : Upper limit Digital comparator and analog comparator detects the current that exceeds 20mA  
 Lower limit Digital comparator

Setting : Setting range Upper limit 0.01~20.00mA  
 Lower limit 0.01~19.99mA/ OFF  
 Resolution 0.01mA

Judgment conditions : Upper limit setting > Leakage current > Lower limit setting ... GOOD  
 Upper limit setting  $\leq$  Leakage current ..... HIGH NG  
 Lower limit setting  $\geq$  Leakage current ..... LOW NG

Judgment accuracy :  $\pm$  (2%+0.05mA) to the set value

• Test time

Setting range : 0.1~99.9/100~999 seconds and OFF (continuous)

Setting resolution : 0.1 second/1 second

During test When the time is set, displays the remaining time.  
 When setting is OFF, displays the elapsed time

At the end of the test Displays remaining time  
 By timer OFF setting during NG judgment Displays the elapsed time

Waiting time Displays the setting value

Accuracy : Set value  $\pm$  (0.1% +20ms)

• Rise/Fall time (Rise time RAISE / Fall time FALL)

Function : The function to raise and fall the test voltage output by setting time

Setting range : 0.1~99.9/100~999 seconds and OFF (OFF is FALL time only)

Setting resolution : 0.1 second/1 second

Accuracy : Set value  $\pm$  (0.1% +20ms)

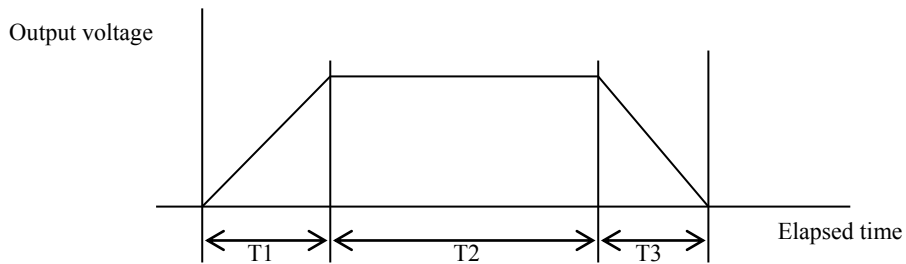

T1 : Rise time  
 T2 : Test time  
 T3 : Fall time  
 Application time = T1 + T2 + T3

## 15. Specifications

### Insulation resistance test

Rated measurement voltage	: DC25V/50V/100V/250V/500V/1000V
No load voltage	: Within 125% of the rated voltage
Rated current	: 1mA
Short-circuit current	: Less than 15mA
Display	: Measured value display 0~9990 Zero suppression Over display (when input open or over)  Displays light
Auto range	: Resolution within measurement range is switched automatically, Rise time is switched at 2000 and fall time is switched at 179 Operation Insulation resistance value is displayed during the test At the end of the test, retains the display of the end time of the test
Externally applied voltage	: Less than 1.2 times measured voltage, Maximum 600V 50/60Hz Less than 10 seconds
Measurement range and Accuracy:	

Rated measurement voltage	Resistance range	Resistance measurement range	Middle value	Resolution	Accuracy	
DC 25V DC 50V	2.000M Ω	0.000~2.000M Ω	500k Ω	1k Ω	±(2%of rdg.+3digit)	
		2.010~4.990M Ω		10k Ω	±30%of rdg.	
	20.00M Ω	1.80~20.00M Ω	5M Ω	10k Ω	±(2%of rdg.+3digit)	
		20.10~49.90M Ω	※	100k Ω	±30%of rdg.	
	200.0M Ω	18.0~100.0M Ω	50M Ω	100k Ω	±(2%of rdg.+3digit)	
		100.1~200.0M Ω		100k Ω	± 5%of rdg.	
		201.0~999.0M Ω		1M Ω	±30%of rdg.	
	DC100V DC250V	2.000M Ω	0.000~2.000M Ω	500k Ω	1k Ω	±(2%of rdg.+3digit)
			2.010~4.990M Ω		10k Ω	±30%of rdg.
20.00M Ω		1.80~20.00M Ω	5M Ω	10k Ω	±(2%of rdg.+3digit)	
		20.10~49.90M Ω	※	100k Ω	±30%of rdg.	
200.0M Ω		18.0~100.0M Ω	50M Ω	100k Ω	±(2%of rdg.+3digit)	
		100.1~200.0M Ω		100k Ω	± 5%of rdg.	
		201.0~499.0M Ω		1M Ω	±30%of rdg.	
2000 M Ω		180 ~2000 M Ω	500M Ω	1M Ω	± 5%of rdg.	
		2010 ~5000 M Ω		10M Ω	±30%of rdg.	
		5010 ~9990 M Ω				
DC 500V DC1000V		20.00M Ω	0.00~20.00M Ω	5M Ω	10k Ω	±(2%of rdg.+3digit)
			20.10~49.90M Ω		100k Ω	±30%of rdg.
	200.0M Ω	18.0~200.0M Ω	50M Ω	100k Ω	±(2%of rdg.+3digit)	
		201.0~499.0M Ω	※	1M Ω	±30%of rdg.	
	2000 M Ω	180 ~1000 M Ω	500M Ω	1M Ω	±(2%of rdg.+3digit)	
		1001 ~2000 M Ω		1M Ω	± 5%of rdg.	
		2010 ~5000 M Ω		10M Ω	±30%of rdg.	
		5010 ~9990 M Ω				

Accuracy: Fixed at the state of 23°C ±5°C, 45~75%RH

Caution: During AUTO range measurement, ※mark becomes the middle value.

• Judgment test results

Judgment method : Upper and lower limit digital comparator  
 Setting range : 0.001~9.999 /10.00~99.99/100.0~999.9/1000~9990  
 Judgment conditions : Upper limit setting > Insulation resistance value > Lower limit setting ... GOOD  
 Upper limit setting  $\leq$  Insulation resistance value ..... HIGH NG  
 Lower limit setting  $\geq$  Insulation resistance value ..... LOW NG

• Test time

Setting range : 0.2~99.9 seconds  
 Setting resolution : 0.1 seconds  
 Accuracy : Setting value  $\pm$  (0.1% +20ms)  
 During test Display remaining time  
 Test end time Display remaining time  
 Waiting time Display setting value  
 Response speed Display response and judgment time  
 Auto range 0.4 seconds (in the middle value)  
 Fixed range 0.2 seconds (in the middle value)

Note) In case of the test object with large ground capacitance, the resistance value measured may become low with the elapse of time. For setting the appropriate time, confirm sufficiently the time to stabilize the measurement value and set the test time so that there is no wrong judgment.

• Mask time

Setting range : 0.1~99.9 seconds  
 Mask time setting < Test time  
 Setting resolution : 0.1 seconds  
 Accuracy : Setting value  $\pm$  (0.1% +20ms)

• Discharging function

It is the function to discharge the electric charge which has been charged in the test specimen during insulation test.

## Memory operation

Memory contents : Memorize the test conditions of withstand voltage test and insulation resistance test  
 Number of pieces : 16 pieces  
 Memory retention : Stored in a non-volatile memory  
 Memory period 10years  
 Readout the memory : Key operation, remote I/O connector, RS-232C, USB  
 Setting method : Key operation, RS-232C, USB

## Program operation

Memory contents : In withstand voltage test, the test conditions can be set in steps and a continuous test is possible.  
 Number of pieces : 16 pieces (0~F)  
 Number of steps : 16 pieces (0~F)  
 Memory retention : Stored in a non-volatile memory.  
 Memory period 10years  
 Read out memory : Key operation, remote I/O connector, RS-232C, USB  
 Setting method : Key operation, RS-232C, USB

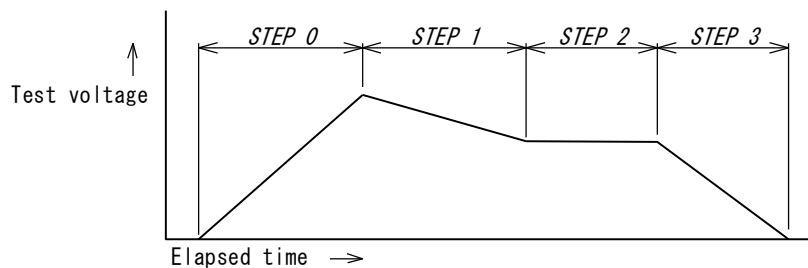

## Other functions

Interlock	: When the rear connector pin is open, it is in locked state.
Key lock	: Depending on the switch operation, it is a function to prohibit switch operation other than key lock.
Buzzer	: Function to ring the buzzer as per the judgment content (OFF setting possible)
Other functions	: ① Double action start After STOP input is off, START signal is valid for 0.5 seconds. ② GOOD hold function 3 conditions can be selected. 0: "GOOD" judgment is output for 0.2 seconds and then returns to the READY state. 1: "GOOD" judgment is retained, after stop signal output, re-started by start signal. 2: "GOOD" judgment is retained, without stop signal, re-started by start signal. ③ Momentary start function START signal performs test during on period. ④ Fail mode function The function to limit the release of NG and PROTECTION to the STOP key of the tester. ⑤ NG Start ON: The start of the test is performed by START signal even when NG judgment is not released by STOP. OFF: After the end of the judgment, NG judgment is retained, released by STOP and the test is started by START signal.

## Input Output signal

Connector	: 36P Amphenol connector
Output signal	: Open collector DC30V 30mA MAX
Output signal name	: TEST : During the test period END : The end TEST/H.V.OUT : During high voltage output READY : In waiting ACW-TEST : During withstand voltage test IR-TEST : During insulation resistance test GOOD : Pass judgment time (0.2s/continuous switchable) NG : Fail judgment time (continuous) ACW HIGH : Withstand voltage upper limit judgment time (continuous) ACW LOW : Withstand voltage lower limit judgment time (continuous) ACW GOOD : Withstand voltage pass judgment time IR HIGH : Insulation upper limit judgment time (continuous) IR LOW : Insulation lower limit judgment time (continuous) IR GOOD : Insulation pass judgment time PROTECTION : Protection function operation
Output signal power supply	: DC24V, 0.1A
Input signal	: H=16.8~24V, L=0~3.8V Ic=10mA, Llabel minimum pulse width=40ms
Input signal name	: START STOP INTER LOCK ACW-MODE IR-MODE REAR MODE

REMOTE I/O connector

Signal name	Pin name		Signal name
+24V	1	19	COM
NC	2	20	REAR MODE
START	3	21	ACW-MODE
STOP	4	22	IR-MODE
INTERLOCK	5	23	COM
MEM SET1	6	24	ACW-TEST
MEM SET2	7	25	IR-TEST
MEM SET4	8	26	TEST
MEM SET8	9	27	MEM SET10
TEST/H.V.OUT	10	28	END
READY	11	29	NC
PROTECTION	12	30	NC
GOOD	13	31	NG
ACW HIGH	14	32	ACW LOW
ACW GOOD	15	33	NC
IR HIGH	16	34	IR LOW
IR GOOD	17	35	NC
NC	18	36	COM

## RS-232C・USB Interface

- Function : Output the setting of the test conditions and test result data.
- Connector : D-Sub 9P
- Transmission system : Asynchronous method
- Transmission speed : 9600 / 19200 / 38400 bps
- Data length : 8bit
- Parity : None/ even/ odd
- Utility software : Optional

■ USB Interface

- Specification : USB 1.1(HID)
- Connector : B type
- Utility software : Optional

## General specification

- Power supply : AC100V ~240V 50/60Hz
- Power supply voltage tolerance range : AC90V~250V
- Power consumption :

power supply	Power consumption	
	Waiting time	Maximum load
100V	About 30VA	About 180VA
200V	About 60VA	About 200VA

- Operating temperature range : 0~40°C
- Operating humidity range : 20~80%RH (Non-condensing)
- Storage temperature : -20~70°C
- Withstand voltage : Power terminal — Between outer box AC1350V 1 minute
- Weight : About 10kg
- Accessories :

High voltage cable	2m	1 piece
Earth wire	3m	1 piece
Power cord	2.5m	1 piece
Remote I/O plug		1 piece
Instruction manual (This book)		1 part
RS-232C·USB Interface manual		1 part

- Option :
- Key cover : 5858-19
- Rack mounting bracket : 5871-03-018
- Power cord for AC200V 3m : 5880-23-030
- Utility software : 5890-15

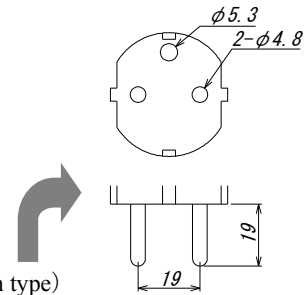

(For Europe 2pole earth with type)

Test setting and recording of test results can be managed from the screen of the computer.

- Accessories: Instruction manual of utility soft 1 set
- CD-R 1 piece
- USB-cable 1.8m

- RS-232C cable 2m : 5881-11-020

## Setting of the default value

Initialize this tester

Hold down the , and keys (①) and turn on the POWER switch.

TEST VOLTAGE and CURRENT/RESISTANCE displays firmware version.  
After 3 seconds, DANGER and JUDGE lamp is off and this tester is initialized.

When the initialization is run, various settings such as test conditions and data that have been saved become the initial value as shown below.

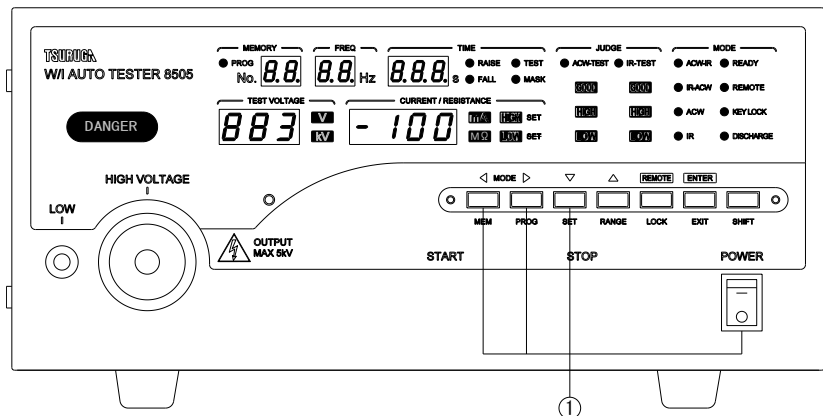

## Default value

Test mode	Withstand voltage test conditions ACW		Insulation resistance test conditions IR	
ACW-IR	Test voltage	0.00kV	Test voltage range	25V
	Upper limit judgment value	10.00mA	Resistance range	AUTO
	Lower limit judgment value	OFF	Upper limit resistance value	OFF
	Voltage rise time	0.1s	Lower limit resistance value	0.001MΩ
	Voltage fall time	OFF	Mask timer time	0.1s
	Test time	60.0s	Test time	0.2s
	Frequency of the test voltage	50Hz		

## Other functions

Functions	Setting value	Contents
Double action	0	Not set
GOOD hold	2	Re-start with no stop signal and hold judgment
Momentary start	0	Not set
FAIL mode	0	Not set
NG start	1	ON
Setting of the buzzer	Pass judgment time	OFF
	Fail judgment time	ON
Interlock	ON	

## Memory operation (No.1~No.16 Common)

Test mode	Withstand voltage test conditions ACW		Insulation resistance test conditions IR	
ACW-IR	Test voltage	0.00kV	Test voltage range	25V
	Upper limit judgment value	10.00mA	Resistance range	AUTO
	Lower limit judgment value	OFF	Upper limit resistance value	OFF
	Voltage rise time	0.1s	Lower limit resistance value	0.001MΩ
	Voltage fall time	OFF	Mask timer time	0.1s
	Test time	60.0s	Test time	0.2s
	Frequency of the test voltage	50Hz		

## Program operation (No.1~No.F common)

It shows the setting value per program.

STEP No.	STEP ON/OFF	Test voltage (kV)	Upper limit judgment value (mA)	Lower limit judgment value (mA)	Timer time (s)	Frequency of the test voltage (Hz)
0	END	0.00	0.50	OFF	0.1	50
1	END	0.00	0.50	OFF	0.1	Depends on the frequency of STEP 0
2	END	0.00	0.50	OFF	0.1	
3	END	0.00	0.50	OFF	0.1	
4	END	0.00	0.50	OFF	0.1	
5	END	0.00	0.50	OFF	0.1	
6	END	0.00	0.50	OFF	0.1	
7 ↓ F	END	0.00	0.50	OFF	0.1	

## Dimensions

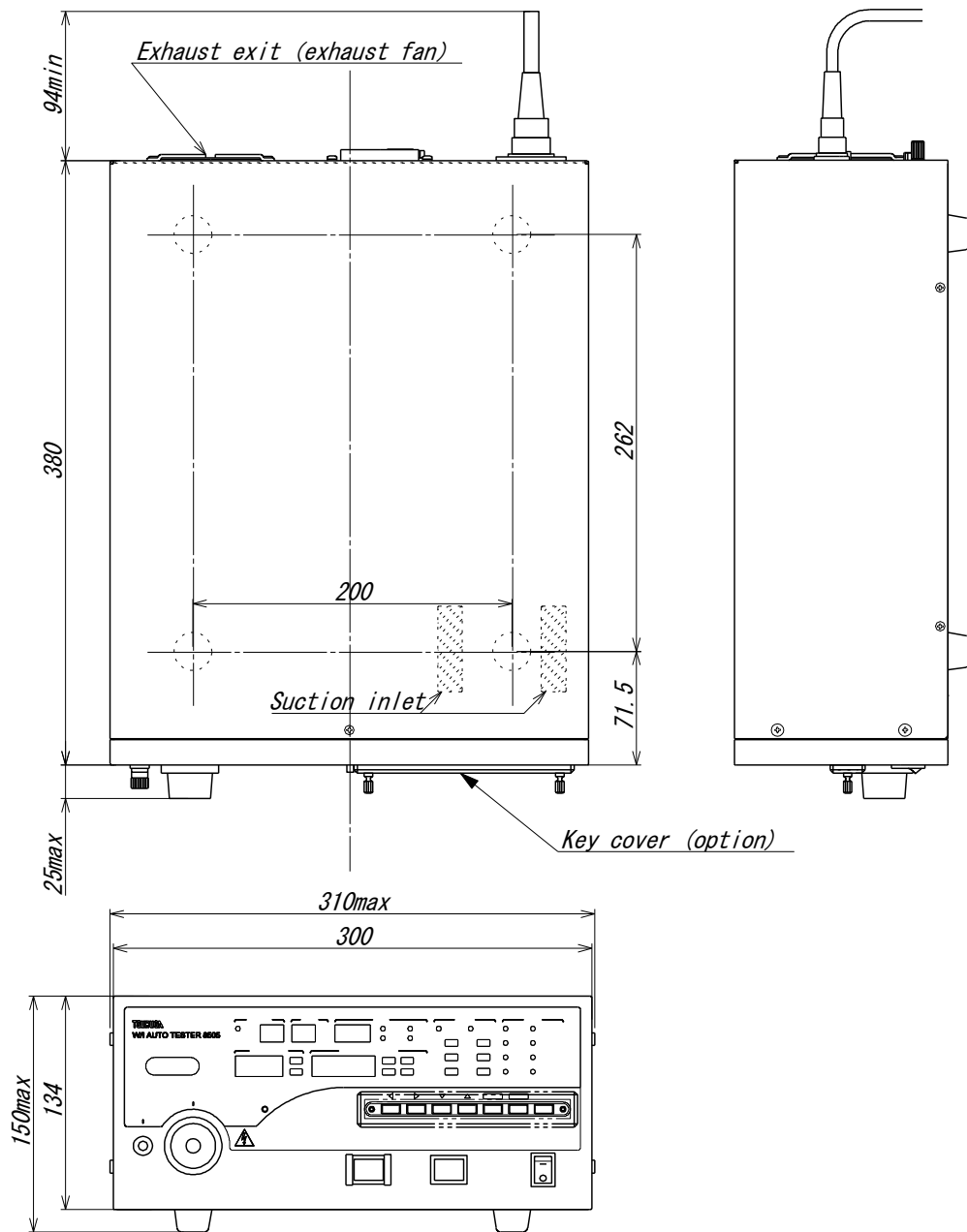





# Tsuruga Electric Corporation

## **Osaka Headquarters**

1-3-23, Minamiumiyoshi, Sumiyoshi-ku, Osaka, Japan 〒558-0041

TEL 81-6 -6692-6700, FAX 81-6 -6609- 8115

E-mail: [cs.info@tsuruga.co.jp](mailto:cs.info@tsuruga.co.jp)

## **Yokohama Office**

1-29-15, Shinyokohama, Kohoku-ku, Yokohama, Kanagawa, Japan 〒222-0033

## **Tokyo Office**

5-25-16, Higashigotanda, Shinagawa-ku, Tokyo, Japan 〒141-0022

## **Nagoya Office**

Sun Park Higashi Betsuin Bld. 2F

5-19, Oicho, Naka-ku, Nagoya, Aichi, Japan 〒460-0015

## **Osaka Plant**

1-3-23, Minami Sumiyoshi, Sumiyoshi-ku, Osaka, Japan 〒558-0041

## **Shiga Plant**

122, Kawasaki-Cho, Nagahama, Shiga, Japan 〒526-0846

[www.tsuruga.co.jp](http://www.tsuruga.co.jp)

# TSURUGA

## MODEL 8505 **RS-232C·USB** Interface

### Instruction Manual



---

---

# Table of contents

---

---

<b>1. External interface .....</b>	<b>1</b>
RS 232C Interface.....	1
<b>2. Connection.....</b>	<b>2</b>
Connector and signal.....	2
Connection to the host (Reference).....	2
<b>3. Setting of this tester to communicate .....</b>	<b>3</b>
Setting items .....	3
Setting method .....	3
<b>4. Before the communication .....</b>	<b>4</b>
<b>5. Structure of command and response .....</b>	<b>5</b>
Structure of Command.....	5
Structure of response.....	5
Response time.....	5
<b>6. Command list .....</b>	<b>6</b>
<b>7. Individual command description .....</b>	<b>7</b>
<b>8. Error code and solution tips .....</b>	<b>20</b>

---

---

# 1. External interface

---

---

## RS 232C Interface

---

### Specification

Even if STOP command and STOP switch are pressed, judgment result of transmission buffer and data are retained till the next start.

Transmission method	Asynchronous Full 2fold
Transmission speed	9600bps,19200bps,38400bps
Data bit length	8-bit
Stop bit	1-bit
Parity bit	None, odd, even
Delimited	CR+LF
Xon/Xoff	None
Receive buffer length	1000 bytes
Connector	D-sub9 pin(male)

### Specification of USB

Specification     USB1.1  
Class             HID class  
Connector        Type B

Note: Cannot be used simultaneously with RS-232C.

## 2. Connection

### Connector and signal

This tester connector D sub 9 pin (male)

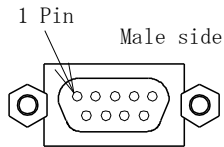

Host side: D sub connector 9 pin (female)

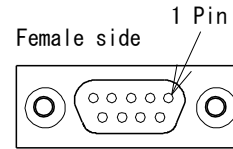

Pin no.	Signal no.	Direction	Name
①			Unused
②	RD (RXD)	←Host	Received data
③	SD (TXD)	→Host	Transmitted data
④	NC		Unused
⑤	SG (GND)		Signal ground
⑥	NC		Unused
⑦	NC		Unused
⑧	NC		Unused
⑨	NC		Unused

Recommended connector:

XM3D-0921 (OMRON)

Recommended hood:

XM2S-0913 (OMRON)

Inch screw

**Note) External connector and cable, Model 5881-11-020, 9 pin-9 pin/2m (optional) are also available.**

### Connection to the host (Reference)

Connection cable: Use a cross cable 5881-11-020.

(If the cable other than the specified is used, there may be the case of communication failure.)

Connection of cable

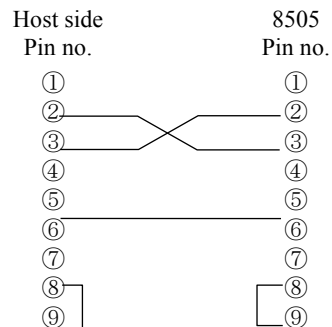

### 3. Setting of this tester to communicate

#### Setting items

Match the setting of ① and ② with communication equipment.

When test is to be performed by communication, set ③ with 「1」.

	Setting item	Setting no.	Factory shipment time
①	Transmission speed	9600bps	0
		19200bps	1
		38400bps	2
②	Parity	None	0
		Odd	1
		Even	2
③	START	Start the test from front panel switch or remote I/O	0
		Start the test depending on START command (in REMOTE state)	1

#### Setting method

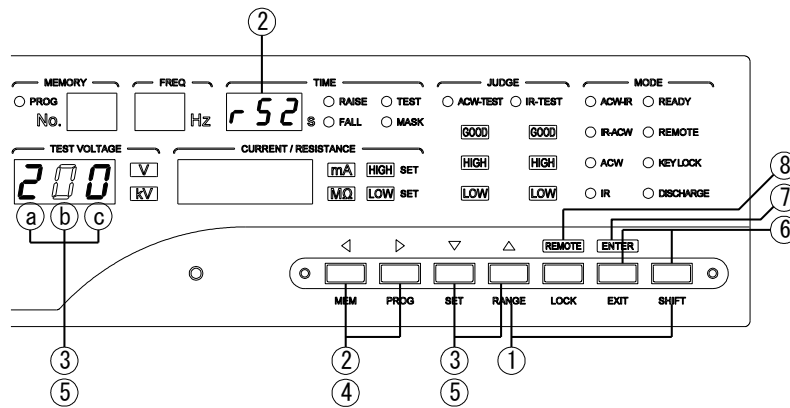

Enter in the setting

- ① Press SET key (SET holding SHIFT) for 3 seconds in READY state.
  - TIME display blinks the light.
- ② Using ◀ and ▶ key, “r 52” is selected.
- ③ Enter in the setting using ▼ key.
  - Setting conditions in TEST VOLTAGE display blinks the light.

Selection of each item

- ④ Using ◀ and ▶ keys, ①Transmission speed ②Parity and ③START are selected.
- ⑤ Using ▲ and ▼ keys, the contents of each item are selected.

End of the setting

- ⑥ When ENTER key is pressed, the setting is stored and returns to READY state.

Interruption of the setting

- ⑦ When EXIT key (EXIT holding SHIFT) is pressed, the setting is interrupted and becomes the READY state. The setting content of that time is the condition that is before entering the setting.

Start of the test

- ⑧ Pressing the REMOTE key, the test is started depending on the START command.

---

## 4. Before the communication

---

 **Caution**

If the command is to be transmitted, make the interlock state in advance.

Avoid to perform key operation setting of this tester and communication setting simultaneously.  
Refer to 8505 Instruction manual "3. Panel operation" of this tester for operation method of the key lock.

---



## 5. Structure of command and response

### Structure of Command

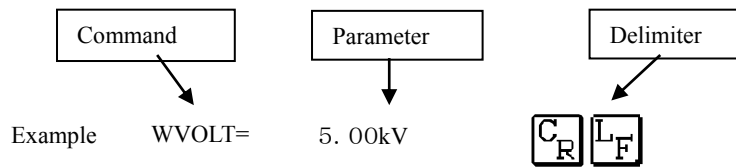

1. Command Command to control 8505  
Upper case and lower case does not matter during command.
2. Delimiter It means there is a break in transmitted data.
3. Command, parameter and delimiter use JIS8 bit code.
4. In case there is no parameter, transmit the delimiter following the command.  
[Example] START CR LF
5. Even if the unit of the parameter is not included, 8505 responses.

#### Caution during command transmission

Transmit setting command (OOOO=) when 8505 is in READY state.

When setting command is transmitted by the host during the test, 8505 transmits to host the "TEST" for the test period.

### Structure of response

In 8505, when command is transmitted to the host, it performs the analysis and processing and returns the response.

When the received data is incompatible, 8505 returns an error code to the host.

Refer to the **tips of the error code and solution for detail**.

[When setting and operation command is valid]

- For valid setting and operation command, **ERROR=0** is always returned to the host.

Example Valid command : In case of START

Response : ERROR=0

[When setting and operation command is invalid]

- For invalid setting and operation command, **ERROR=error code** is always returned to the host.

Example Invalid command : STAT...when there is a mistake in spelling during test interruption

Response : ERROR=1

### Response time

As the response time of command list of next page is the reference value, it changes depending on the condition of use.



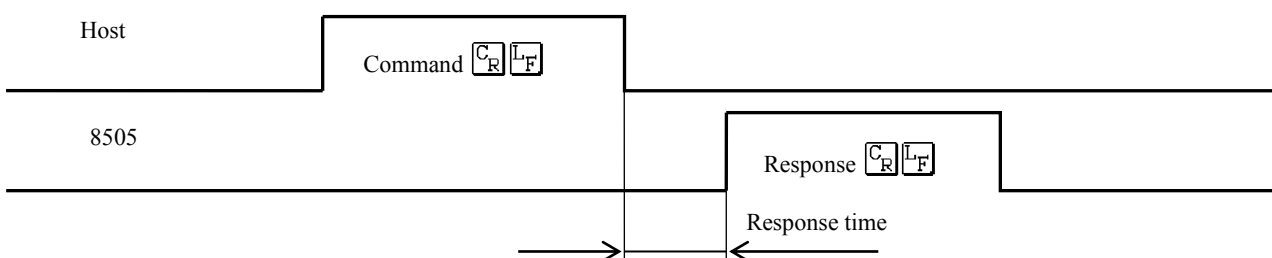

















The performance of 8505 is not guaranteed.























## 6. Command list





















Description		Command	Page	Response time	
Reading the device information		<b>IDNT?</b>	7	About 15ms	
Reading of the state		<b>STATUS?</b>	7		
Remote control	Setting	<b>REMOTE=</b>	7		
	Reading	<b>REMOTE ?</b>	7		
Key lock	Setting	<b>KEYLOCK=</b>	8		
	Reading	<b>KEYLOCK ?</b>	8		
Start of the test		<b>START</b>	8		
Discontinuation of the test, Judgment reset		<b>STOP</b>	8		
Setting mode	Setting	<b>MODE=</b>	8		
	Reading	<b>MODE?</b>	8		
Withstand voltage test	Test voltage	Setting	<b>WVOLT=</b>		8
		Reading	<b>WVOLT?</b>		9
	Upper limit judgment value	Setting	<b>WHIGH=</b>		9
		Reading	<b>WHIGH?</b>		9
	Lower limit judgment value	Setting	<b>WLOW=</b>		9
		Reading	<b>WLOW?</b>		9
	Test time	Setting	<b>WTIMER=</b>		9
		Reading	<b>WTIMER?</b>		9
	Voltage rise time	Setting	<b>WRTIMER=</b>		9
		Reading	<b>WRTIMER?</b>		9
	Voltage fall time	Setting	<b>WFTIMER=</b>		10
		Reading	<b>WFTIMER?</b>		10
	Frequency	Setting	<b>WFREQ=</b>		10
		Reading	<b>WFREQ?</b>	10	
Insulation resistance test	Test voltage	Setting	<b>IVOLT=</b>	10	
		Reading	<b>IVOLT?</b>	10	
	Resistance range	Setting	<b>IRANGE=</b>	10	
		Reading	<b>IRANGE?</b>	10	
	Upper limit judgment value	Setting	<b>IHIGH=</b>	11	
		Reading	<b>IHIGH?</b>	11	
	Lower limit judgment value	Setting	<b>ILOW=</b>	11	
		Reading	<b>ILOW?</b>	11	
	Mask time	Setting	<b>IMASK=</b>	11	
		Reading	<b>IMASK?</b>	11	
	Test time	Setting	<b>ITIMER=</b>	11	
		Reading	<b>ITIMER?</b>	11	
Reading of test result and data in a bulk		Reading	<b>DATA?</b>	12	
Panel setting mode test conditions		Setting	<b>SET=</b>	14	
		Reading	<b>SET?</b>	14	
Switching of memory No.	1~16	Setting	<b>MEMORY=</b>	15	
		Reading	<b>MEMORY?</b>	15	
Test conditions of memory	1~16	Setting	<b>MEM□=</b>	15	
		Reading	<b>MEM□ ?</b>	16	
Switching of program No.	0~F	Setting	<b>PROGRAM=</b>	16	
		Reading	<b>PROGRAM?</b>	16	
Test conditions of program	0~F	Setting	<b>PROG□=</b>	17	
		Reading	<b>PROG□?</b>	18	
Reading of program and test result in a bulk		Reading	<b>PROGDATA?</b>	19	

























## 7. Individual command description

1) <b>IDNT?</b>	Reading of the device information																																																																																																				
	Syntax <b>IDNT?</b>																																																																																																				
	Transmission <b>IDNT?</b>  																																																																																																				
	Response <b>IDNT=</b> ①,②,③   <p>① Maker name <b>TSURUGA</b>            ② Model name <b>8505</b>            ③ Software version <b>883-100</b> (Example)</p>																																																																																																				
2) <b>STATUS?</b>	Reading of the 8505 state																																																																																																				
	Syntax <b>STATUS?</b>																																																																																																				
	Transmission <b>STATUS?</b>  																																																																																																				
	Response <b>STATUS=</b> ①,②,③,④  																																																																																																				
	Types of parameters																																																																																																				
	<table border="1"> <thead> <tr> <th colspan="4">Weight of the data</th> <th rowspan="2">Parameter</th> <th rowspan="2">Output signal name</th> </tr> <tr> <th>①</th> <th>②</th> <th>③</th> <th>④</th> </tr> </thead> <tbody> <tr> <td>0</td> <td>0</td> <td>0</td> <td>1</td> <td>TEST</td> <td>Under test</td> </tr> <tr> <td>0</td> <td>0</td> <td>0</td> <td>2</td> <td>END</td> <td>Test end</td> </tr> <tr> <td>0</td> <td>0</td> <td>0</td> <td>4</td> <td>TEST/H.V.OUT</td> <td>Under high voltage output</td> </tr> <tr> <td>0</td> <td>0</td> <td>0</td> <td>8</td> <td>READY</td> <td>READY state</td> </tr> <tr> <td>0</td> <td>0</td> <td>1</td> <td>0</td> <td>ACW-TEST</td> <td>Under withstand voltage test</td> </tr> <tr> <td>0</td> <td>0</td> <td>2</td> <td>0</td> <td>IR-TEST</td> <td>Under insulation resistance test</td> </tr> <tr> <td>0</td> <td>0</td> <td>4</td> <td>0</td> <td>GOOD</td> <td>Pass judgment</td> </tr> <tr> <td>0</td> <td>0</td> <td>8</td> <td>0</td> <td>NG</td> <td>Fail judgment</td> </tr> <tr> <td>0</td> <td>1</td> <td>0</td> <td>0</td> <td>ACW HIGH</td> <td>Withstand voltage test upper limit judgment</td> </tr> <tr> <td>0</td> <td>2</td> <td>0</td> <td>0</td> <td>ACW LOW</td> <td>Withstand voltage test lower limit judgment</td> </tr> <tr> <td>0</td> <td>4</td> <td>0</td> <td>0</td> <td>ACW GOOD</td> <td>Withstand voltage test pass</td> </tr> <tr> <td>0</td> <td>8</td> <td>0</td> <td>0</td> <td>IR HIGH</td> <td>Insulation resistance test upper limit judgment</td> </tr> <tr> <td>1</td> <td>0</td> <td>0</td> <td>0</td> <td>IR LOW</td> <td>Insulation resistance test lower limit judgment</td> </tr> <tr> <td>2</td> <td>0</td> <td>0</td> <td>0</td> <td>IR GOOD</td> <td>Insulation resistance test pass</td> </tr> <tr> <td>4</td> <td>0</td> <td>0</td> <td>0</td> <td>PROTECTION</td> <td>Protection operation function</td> </tr> </tbody> </table>	Weight of the data				Parameter	Output signal name	①	②	③	④	0	0	0	1	TEST	Under test	0	0	0	2	END	Test end	0	0	0	4	TEST/H.V.OUT	Under high voltage output	0	0	0	8	READY	READY state	0	0	1	0	ACW-TEST	Under withstand voltage test	0	0	2	0	IR-TEST	Under insulation resistance test	0	0	4	0	GOOD	Pass judgment	0	0	8	0	NG	Fail judgment	0	1	0	0	ACW HIGH	Withstand voltage test upper limit judgment	0	2	0	0	ACW LOW	Withstand voltage test lower limit judgment	0	4	0	0	ACW GOOD	Withstand voltage test pass	0	8	0	0	IR HIGH	Insulation resistance test upper limit judgment	1	0	0	0	IR LOW	Insulation resistance test lower limit judgment	2	0	0	0	IR GOOD	Insulation resistance test pass	4	0	0	0	PROTECTION	Protection operation function
	Weight of the data				Parameter			Output signal name																																																																																													
	①	②	③	④																																																																																																	
	0	0	0	1	TEST	Under test																																																																																															
	0	0	0	2	END	Test end																																																																																															
0	0	0	4	TEST/H.V.OUT	Under high voltage output																																																																																																
0	0	0	8	READY	READY state																																																																																																
0	0	1	0	ACW-TEST	Under withstand voltage test																																																																																																
0	0	2	0	IR-TEST	Under insulation resistance test																																																																																																
0	0	4	0	GOOD	Pass judgment																																																																																																
0	0	8	0	NG	Fail judgment																																																																																																
0	1	0	0	ACW HIGH	Withstand voltage test upper limit judgment																																																																																																
0	2	0	0	ACW LOW	Withstand voltage test lower limit judgment																																																																																																
0	4	0	0	ACW GOOD	Withstand voltage test pass																																																																																																
0	8	0	0	IR HIGH	Insulation resistance test upper limit judgment																																																																																																
1	0	0	0	IR LOW	Insulation resistance test lower limit judgment																																																																																																
2	0	0	0	IR GOOD	Insulation resistance test pass																																																																																																
4	0	0	0	PROTECTION	Protection operation function																																																																																																
Response example																																																																																																					
Example1 <b>STATUS=0025</b>   IR-TEST+TEST+TEST/H.V.OUT Under insulation resistance test, under test, under high voltage output																																																																																																					
Example2 <b>STATUS=2442</b>   IR GOOD+ACW GOOD+GOOD+END Insulation resistance test pass, withstand voltage test pass, pass judgment, Test end																																																																																																					
3) <b>REMOTE=</b>	Set the remote control																																																																																																				
	Syntax <b>REMOTE=</b> [ON/OFF]																																																																																																				
	Transmission <b>REMOTE=</b> [ON/OFF]  																																																																																																				
4) <b>REMOTE?</b>	Reading of the remote control state																																																																																																				
	Syntax <b>REMOTE?</b>																																																																																																				
	Transmission <b>REMOTE?</b>  																																																																																																				
	Response <b>REMOTE=</b> ON   <b>REMOTE=</b> OFF  																																																																																																				

5) <b>KEYLOCK=</b>	Set the key lock
	Syntax <b>KEYLOCK=[ON/OFF]</b>
	Transmission <b>KEYLOCK=[ON/OFF]</b>  
6) <b>KEYLOCK?</b>	Reading of the key lock state
	Syntax <b>KEYLOCK?</b>
	Transmission <b>KEYLOCK?</b>  
	Response <b>KEYLOCK=ON</b>   <b>KEYLOCK=OFF</b>  
7) <b>START</b>	Test is started in READY state.
	Syntax <b>START</b>
	Transmission <b>START</b>  
	Besides READY state, when RS-232C function setting of external control is START"0", ERROR=6 is returned.
8) <b>STOP</b>	Discontinuation of the test. When run in the state of judgment issued, returns to the READY state.
	Syntax <b>STOP</b>
	Transmission <b>STOP</b>  
9) <b>MODE=</b>	Set the test mode
	Syntax <b>MODE=[Parameter]</b> [Parameter]
	<b>ACWIR:</b> Withstand voltage test → Automatic continuous test mode of insulation resistance test
	<b>IRACW:</b> Insulation resistance test → Automatic continuous test mode of withstand voltage test
	<b>ACW:</b> Individual test mode of withstand voltage test <b>IR:</b> Individual test mode of insulation resistance test <b>PROG:</b> Program operation <b>MEM:</b> Memory operation
Transmission <b>MODE= ACWIR</b>  	
Test mode a withstand voltage test → Setting of automatic continuous test mode of insulation resistance test.	
10) <b>MODE?</b>	Reading of the set test mode contents.
	Syntax <b>MODE?</b>
	Transmission <b>MODE?</b>  
	Response <b>MODE=[Parameter]</b>   [Parameter]
<b>ACWIR:</b> Withstand voltage test → Automatic continuous test mode of insulation resistance test	
<b>IRACW:</b> Insulation resistance test → Automatic continuous test mode of withstand voltage test	
<b>ACW:</b> Individual test mode of withstand voltage test <b>IR:</b> Individual test mode of insulation resistance test <b>PROG:</b> Program operation <b>MEM:</b> Memory operation	
11) <b>WVOLT=</b>	Set the test voltage of withstand voltage test.
	Syntax <b>WVOLT=[Parameter]</b> [Parameter]: <b>0.00kV~5.50kV</b>
	Transmission <b>WVOLT=5.00kV</b>   Set the test voltage of withstand voltage test to 5.00kV.

12) <b>WVOLT?</b>	Reading of the test voltage of withstand voltage test.
	Syntax <b>WVOLT?</b>
	Transmission <b>WVOLT?</b> <input type="checkbox"/> <input type="checkbox"/>
	Response <b>WVOLT</b> =[Parameter] <input type="checkbox"/> <input type="checkbox"/> [Parameter] : <b>0.00kV~5.50kV</b>
13) <b>WHIGH=</b>	Set the upper limit judgment value of withstand voltage test.
	Syntax <b>WHIGH</b> =[Parameter] [Parameter] : <b>0.01mA~20.00mA</b>
	Transmission <b>WHIGH</b> = <b>10.00mA</b> <input type="checkbox"/> <input type="checkbox"/> Set the upper limit judgment value of withstand voltage test to 10.00mA.
14) <b>WHIGH?</b>	Reading of the upper limit judgment value of withstand voltage test.
	Syntax <b>WHIGH?</b>
	Transmission <b>WHIGH?</b> <input type="checkbox"/> <input type="checkbox"/>
	Response <b>WHIGH</b> =[Parameter] <input type="checkbox"/> <input type="checkbox"/> [Parameter] : <b>0.01mA~20.00mA</b>
15) <b>WLOW=</b>	Set the lower limit judgment value of withstand voltage test.
	Syntax <b>WLOW</b> =[Parameter] [Parameter] : Set to <b>OFF</b> or <b>0.01mA~19.99mA</b> .
	Transmission <b>WLOW</b> = <b>2.00mA</b> <input type="checkbox"/> <input type="checkbox"/> Set the lower limit judgment value of withstand voltage test to 2.00mA.
16) <b>WLOW?</b>	Reading of the lower limit judgment value of withstand voltage test.
	Syntax <b>WLOW?</b>
	Transmission <b>WLOW?</b> <input type="checkbox"/> <input type="checkbox"/>
	Response <b>WLOW</b> =[Parameter] <input type="checkbox"/> <input type="checkbox"/> [Parameter] : <b>OFF</b> or <b>0.01mA~19.99mA</b>
17) <b>WTIMER=</b>	Set the test time of withstand voltage test.
	Syntax <b>WTIMER</b> =[Parameter] [Parameter] : Set to <b>OFF</b> or <b>0.1s~99.9s/100s~999s</b> .
	Transmission <b>WTIMER</b> = <b>60.0s</b> <input type="checkbox"/> <input type="checkbox"/> Set the test time of withstand voltage test to 60.0 seconds.
18) <b>WTIMER?</b>	Reading of the test time of withstand voltage test is done.
	Syntax <b>WTIMER?</b>
	Transmission <b>WTIMER?</b> <input type="checkbox"/> <input type="checkbox"/>
	Response <b>WTIMER</b> =[Parameter] <input type="checkbox"/> <input type="checkbox"/> [Parameter] : <b>OFF</b> or <b>0.1s~99.9s/100s~999s</b>
19) <b>WRTIMER=</b>	Setting of the voltage rise time of withstand voltage test.
	Syntax <b>WRTIMER</b> =[Parameter] [Parameter] : Set to <b>0.1s~99.9s/100s~999s</b>
	Transmission <b>WRTIMER</b> = <b>10.0s</b> <input type="checkbox"/> <input type="checkbox"/> Set the rise time of the withstand voltage test to 10.0 seconds.
20) <b>WRTIMER?</b>	Reading of the voltage rise time of the withstand voltage test.
	Syntax <b>WRTIMER?</b>
	Transmission <b>WRTIMER?</b> <input type="checkbox"/> <input type="checkbox"/>
	Response <b>WRTIMER</b> =[Parameter] <input type="checkbox"/> <input type="checkbox"/> [Parameter] : <b>0.1s~99.9s/100s~999s</b>

21) <b>WFTIMER=</b>	Setting of the voltage fall time of withstand voltage test.
	Syntax <b>WFTIMER=[Parameter]</b> [Parameter]: Set to <b>OFF</b> or <b>0.1s~99.9s/100s~999s</b> .
	Transmission <b>WFTIMER=60.0s</b>   Set the test time of withstand voltage test to 60.0 seconds.
22) <b>WFTIMER?</b>	Reading of the voltage fall time of the withstand voltage test.
	Syntax <b>WFTIMER?</b>
	Transmission <b>WFTIMER?</b>  
	Response <b>WFTIMER=[Parameter]</b>   [Parameter]: <b>OFF</b> or <b>0.1s~99.9s/100s~999s</b>
23) <b>WFREQ=</b>	Setting of the test voltage frequency of withstand voltage test.
	Syntax <b>WFREQ=[Parameter]</b>
	Transmission <b>WFREQ?</b>  
	Response <b>WFREQ=[Parameter]</b>   [Parameter]: <b>50Hz</b> or <b>60Hz</b>
24) <b>WFREQ?</b>	Reading of the test voltage frequency of withstand voltage test.
	Syntax <b>WFREQ?</b>
	Transmission <b>WFREQ?</b>  
	Response <b>WFREQ=[Parameter]</b>   [Parameter]: <b>50Hz</b> or <b>60Hz</b>
25) <b>IVOLT=</b>	Setting of the test voltage of insulation resistance test.
	Syntax <b>IVOLT=[Parameter]</b> [Parameter]: <b>25V,50V,100V,250V,500V,1000V</b>
	Transmission <b>IVOLT=1000V</b>   Set test voltage of insulation resistance test to 1000V.
26) <b>IVOLT?</b>	Reading of the test voltage of insulation resistance test.
	Syntax <b>IVOLT?</b>
	Transmission <b>IVOLT?</b>  
	Response <b>IVOLT=[Parameter]</b>   [Parameter]: <b>25V,50V,100V,250V,500V,1000V</b>
27) <b>IRANGE=</b>	Setting of the resistance range of the insulation resistance test.
	Syntax <b>IRANGE=[Parameter]</b> [Parameter]: <b>2.000MOHM, 20.00MOHM, 200.0MOHM, 2000MOHM, AUTO</b>
	Transmission <b>IRANGE=AUTO</b>   Set the resistance range of insulation resistance test to auto range.
28) <b>IRANGE ?</b>	Reading of resistance range of insulation resistance test.
	Syntax <b>IRANGE ?</b>
	Transmission <b>IRANGE?</b>  
	Response <b>IRANGE=[Parameter]</b> [Parameter]: <b>2.000MOHM, 20.00MOHM, 200.0MOHM, 2000MOHM, AUTO</b>





29) <b>IHIGH=</b>	Setting of the upper limit judgment value of insulation resistance test.
	Syntax <b>IHIGH=</b> [Parameter] [Parameter]: <b>OFF</b> or <b>0.001MOHM~9990MOHM</b>
	Transmission <b>IHIGH=100.0MOHM</b>   Set the upper limit judgment value of insulation resistance test to 100.0MΩ.
30) <b>IHIGH?</b>	Reading of the upper limit judgment value of insulation resistance test.
	Syntax <b>IHIGH?</b>
	Transmission <b>IHIGH?</b>   Response <b>IHIGH=</b> [Parameter]   [Parameter]: <b>OFF</b> or <b>0.001MOHM~9990MOHM</b>
31) <b>ILOW=</b>	Setting of the lower limit judgment value of the insulation resistance test.
	Syntax <b>ILOW=</b> [Parameter] [Parameter]: <b>0.001MOHM~9990MOHM</b>
	Transmission <b>ILOW=0.2MOHM</b>   Set the lower limit judgment value of insulation resistance test to 0.2MΩ.
32) <b>ILOW?</b>	Reading of the lower limit judgment value of the insulation resistance test.
	Syntax <b>ILOW?</b>
	Transmission <b>ILOW?</b>   Response <b>ILOW=</b> [Parameter]   [Parameter]: <b>0.001MOHM~9990MOHM</b>
33) <b>IMASK=</b>	Setting of the mask time of the insulation resistance test.
	Syntax <b>IMASK=</b> [Parameter] [Parameter]: <b>0.1~99.9s</b> Note) Mask time cannot be set more than test time (ITIMER).
	Transmission <b>IMASK=5.0s</b>   Set the mask time of insulation resistance test to 5.0 seconds.
34) <b>IMASK?</b>	Reading of the mask time of insulation resistance test.
	Syntax <b>IMASK?</b>
	Transmission <b>IMASK?</b>   Response <b>IMASK=</b> [Parameter]   [Parameter]: <b>0.1~99.9s</b>
35) <b>ITIMER=</b>	Setting of the test time of the insulation resistance test.
	Syntax <b>ITIMER=</b> [Parameter] [Parameter]: <b>OFF</b> or <b>0.2~99.9s</b> Note) Test time cannot be set less than mask time (IMASK).
	Transmission <b>ITIMER=60.0s</b>   Set the test time of insulation resistance test to 60.0 seconds.
36) <b>ITIMER?</b>	Reading of the test time of the insulation resistance test.
	Syntax <b>ITIMER?</b>
	Transmission <b>ITIMER?</b>   Response <b>ITIMER=</b> [Parameter]   [Parameter]: <b>OFF</b> or <b>0.2~99.9s</b>

**37) DATA?**

Reading of the test result.			
Command used after the end of the test.			
Syntax <b>DATA?</b>			
Transmission <b>DATA?</b> <input type="checkbox"/> <input type="checkbox"/>			
Response <b>DATA=</b> ①,②,③,④,⑤,⑥,⑦,⑧,⑨,⑩ <input type="checkbox"/> <input type="checkbox"/>			
Test mode			
	ACW-IR or IR-ACW	ACW Individual test	IR Individual test
①	<b>JUDGE=</b>	<b>JUDGE=</b>	<b>JUDGE=</b>
②	<b>WJUDGE=</b>	<b>WJUDGE=</b>	<b>IJUDGE=</b>
③	<b>WVOLT=</b>	<b>WVOLT=</b>	<b>RESISTANCE=</b>
④	<b>CURRENT=</b>	<b>CURRENT=</b>	<b>IMTIMER=</b>
⑤	<b>WMTIMER=</b>	<b>WMTIMER=</b>	<b>T</b> (Types of timer at end time)
⑥	Types of timer at end time	Types of timer at end time	
⑦	<b>IJUDGE=</b>		
⑧	<b>RESISTANCE=</b>		
⑨	<b>IMTIMER=</b>		
⑩	<b>T</b> (Types of timer at end time)		
Parameter		Contents	
<b>JUDGE=</b>	<b>GOOD</b>	Pass	Synthetic judgment
	<b>NG</b>	Fail	
	<b>NULL</b>	Interrupts the test by STOP	
	<b>PROTECT</b>	Protection function operates during test	
<b>WJUDGE=</b>	<b>GOOD</b>	Pass	Withstand voltage test
	<b>HIGH</b>	Time of upper limit judgment	
	<b>LOW</b>	Time of lower limit judgment	
	<b>NULL</b>	Interrupts the test by STOP	
	<b>HIGH LOW</b>	Protection function operates during test	
<b>WVOLT=</b>	<b>0.00kV</b>	Measured value of the test voltage	
	<b>NULL</b>	Interrupts the test by STOP	
<b>CURRENT=</b>	<b>0.00mA</b>	Measured value of the leakage current	
	<b>OVER</b>	Measured value is over	
	<b>NULL</b>	Interrupts the test by STOP	
<b>WMTIMER=</b>	<b>0.0s</b>	Remaining time of the timer after test end During <b>WMTIMER=OFF</b> , Elapsed time	
Types of timer	<b>R</b>	End with the rise time	
	<b>T</b>	End with the test time	
	<b>F</b>	End with the fall time	
<b>IJUDGE=</b>	<b>GOOD</b>	Pass	Insulation resistance test
	<b>HIGH</b>	During upper limit judgment	
	<b>LOW</b>	During lower limit judgment	
	<b>NULL</b>	Abort the test with STOP	
<b>RESISTANCE=</b>	<b>1000MOHM</b>	Insulation resistance measurement value (display value)	
	<b>OVER</b>	Measurement value is over	
	<b>UNDER</b>	Measurement value is under	
	<b>NULL</b>	Abort the test with STOP	
<b>IMTIMER=</b>	<b>0.0s</b>	Remaining time of the test	



## Response example of "DATA?"

ACW Test	During GOOD judgment <b>DATA=JUDGE=GOOD,WJUDGE=GOOD,WVOLT=1.00kV,CURRENT=0.05mA,WMTIMER=0.0s,F</b>  
	During HIGH judgment <b>DATA=JUDGE=NG,WJUDGE=HIGH,WVOLT=1.50kV,CURRENT=10.00mA,WMTIMER=0.1s,T</b>  
	During test and when RESET <b>DATA=JUDGE=NULL,WJUDGE=NULL,WVOLT=NULL,CURRENT=NULL,WMTIME=NULL,T</b>
	During occurrence of Protect <b>DATA=JUDGE=PROTECT,WJUDGE=HIGH LOW,WVOLT=NULL,CURRENT=NULL,WMTIME=NULL,T</b>
IR Test	During GOOD judgment <b>DATA=JUDGE=GOOD,IJUDGE=GOOD,RESISTANCE=40.0MOHM,IMTIME=0.0s,T</b>
	During LOW judgment <b>DATA=JUDGE=NG,IJUDGE=LOW,RESISTANCE=20.0MOHM,IMTIME=3.0s,T</b>
	During test and when RESET <b>DATA=JUDGE=DATA=JUDGE=NULL,IJUDGE=NULL,RESISTANCE=NULL,IMTIME=NULL,T</b>
	During occurrence of Protect <b>DATA=JUDGE= PROTECT,IJUDGE=HIGH LOW,RESISTANCE=NULL,IMTIME=NULL,T</b>
ACW – IR Test	During GOOD judgment <b>DATA=JUDGE=GOOD,WJUDGE=GOOD,WVOLT=0.12kV,CURRENT=0.57mA,WMTIME=0.0s,F,IJUDGE=GOOD,RESISTANCE=0.205MOHM,IMTIME=0.0s,T</b>
	During ACW HIGH judgment <b>DATA=JUDGE=NG,WJUDGE=HIGH,WVOLT=2.10kV,CURRENT=10.18mA,WMTIME=0.1s,R,IJUDGE=NULL,RESISTANCE=NULL,IMTIME=NULL,T</b>
	During IR LOW judgment <b>DATA=JUDGE=NG,WJUDGE=GOOD,WVOLT=0.12kV,CURRENT=0.57mA,WMTIME=0.0s,F,IJUDGE=LOW,RESISTANCE=0.205MOHM,IMTIME=3.0s,T</b>
IR – ACW Test	During GOOD judgment <b>DATA=JUDGE=GOOD,WJUDGE=GOOD,WVOLT=0.12kV,CURRENT=0.57mA,WMTIME=0.0s,F,IJUDGE=GOOD,RESISTANCE=0.205MOHM,IMTIME=0.0s,T</b>
	During IR LOW judgment <b>DATA=JUDGE=NG,WJUDGE=NULL,WVOLT=NULL,CURRENT=NULL,WMTIME=NULL,T,IJUDGE=LOW,RESISTANCE=0.205MOHM,IMTIME=3.0s,T</b>
	During ACW HIGH judgment <b>DATA=JUDGE=NG,WJUDGE=HIGH,WVOLT=2.10kV,CURRENT=10.18mA,WMTIME=0.1s,R,IJUDGE=GOOD,RESISTANCE=0.205MOHM,IMTIME=0.0s,T</b>
ACW – IR Test or IR – ACW Test	During test and when RESET <b>DATA=JUDGE=NULL,WJUDGE=NULL,WVOLT=NULL,CURRENT=NULL,WMTIME=NULL,T,IJUDGE=NULL,RESISTANCE=NULL,IMTIME=NULL,T</b>
	During occurrence of Protect <b>DATA=JUDGE=PROTECT,WJUDGE=HIGH LOW,WVOLT=NULL,CURRENT=NULL,WMTIME=NULL,T,IJUDGE=HIGH LOW,RESISTANCE=NULL,IMTIME=NULL,T</b>



※The data which cannot be tested becomes「NULL」. The test data which is ended by automatic test is retained.

**38) SET=**

Parameter of test conditions is set.



Command order, replacement not possible

**Syntax**        **SET=**

**Transmission** **SET=**①,②,③,④,⑤,⑥,⑦,⑧,⑨,⑩,⑪,⑫,⑬,⑭  

	Test mode		
	ACW-I or IR-ACW	ACW Individual test	IR Individual test
①	<b>MODE=</b>	<b>MODE=</b>	<b>MODE=</b>
②	<b>WVOLT=</b>	<b>WVOLT=</b>	<b>IVOLT=</b>
③	<b>WHIGH=</b>	<b>WHIGH=</b>	<b>IRANGE=</b>
④	<b>WLOW=</b>	<b>WLOW=</b>	<b>IHIGH=</b>
⑤	<b>WTIMER=</b>	<b>WTIMER=</b>	<b>ILOW=</b>
⑥	<b>WRTIMER=</b>	<b>WRTIMER=</b>	<b>IMASK=</b>
⑦	<b>WFTIMER=</b>	<b>WFTIMER=</b>	<b>ITIMER=</b>
⑧	<b>WFREQ=</b>	<b>WFREQ=</b>	
⑨	<b>IVOLT=</b>		
⑩	<b>IRANGE=</b>		
⑪	<b>IHIGH=</b>		
⑫	<b>ILOW=</b>		
⑬	<b>IMASK=</b>		
⑭	<b>ITIMER=</b>		



For detail of each command, refer to the respective command descriptions.



Transmission example    SET=MODE=ACWIR, WVOLT=2.50kV,WHIGH=20.00mA,WLOW=OFF, WTIMER=10.0s,WRTIMER=5.0s,WFTIMER=10.0s,WFRQ=60Hz,IVOLT=500V, IRANGI=AUTO,IHIGH=OFF,ILOW=10.00MOHM,IMASK=1.0s,ITIMER=60.0s  

**39) SET?**

Parameter of test conditions is read out.



**Syntax**        **SET?**







**Transmission** **SET?**  













**Response**     **SET?=**①,②,③,④,⑤,⑥,⑦,⑧,⑨,⑩,⑪,⑫,⑬,⑭  

	Test mode		
	ACW-IR or IR-ACW	ACW Individual test	IR Individual test
①	<b>MODE=</b>	<b>MODE=</b>	<b>MODE=</b>
②	<b>WVOLT=</b>	<b>WVOLT=</b>	<b>IVOLT=</b>
③	<b>WHIGH=</b>	<b>WHIGH=</b>	<b>IRANGE=</b>
④	<b>WLOW=</b>	<b>WLOW=</b>	<b>IHIGH=</b>
⑤	<b>WTIMER=</b>	<b>WTIMER=</b>	<b>ILOW=</b>
⑥	<b>WRTIMER=</b>	<b>WRTIMER=</b>	<b>IMASK=</b>
⑦	<b>WFTIMER=</b>	<b>WFTIMER=</b>	<b>ITIMER=</b>
⑧	<b>WFREQ=</b>	<b>WFREQ=</b>	
⑨	<b>IVOLT=</b>		
⑩	<b>IRANGE=</b>		
⑪	<b>IHIGH=</b>		
⑫	<b>ILOW=</b>		
⑬	<b>IMASK=</b>		
⑭	<b>ITIMER=</b>		

For detail of each command, refer to the respective command descriptions.

Response example        SET=MODE=ACWIR, WVOLT=2.50kV,WHIGH=20.00mA,WLOW=OFF, WTIMER=10.0s,WRTIMER=5.0s,WFTIMER=10.0s,WFREQ=60Hz,IVOLT=500V, IRANGE=AUTO,IHIGH=OFF,ILOW=50.00MOHM,IMASK=1.0s,ITIMER=60.0s  

<b>40) MEMORY=</b>	Setting of the Memory No.			
	Syntax	<b>MEMORY=[Parameter]</b> [Parameter]: <b>1~16</b>		
	Transmission	<b>MEMORY=5</b>   Memory No. is specified to「5」.		
<b>41) MEMORY?</b>	Memory No. is read out.			
	Syntax	<b>MEMORY?</b>		
	Transmission	<b>MEMORY?</b>  		
	Response	<b>MEMORY=8</b>   When memory No. 8 is read out		
<b>42) MEM□=</b>	Test mode and parameter are set to the specified memory No. Command order replacement not possible			
	Syntax	<b>MEM [Memory No.]=①,②,③,④,⑤,⑥,⑦,⑧,⑨,⑩,⑪,⑫,⑬,⑭,⑮</b> [Memory No.]: <b>1~16</b>		
		Test mode		
		ACW-IR or IR-ACW	ACW Individual test	IR Individual test
	①	<b>MODE=</b>	<b>MODE=</b>	<b>MODE=</b>
	②	<b>WVOLT=</b>	<b>WVOLT=</b>	<b>IVOLT=</b>
	③	<b>WHIGH=</b>	<b>WHIGH=</b>	<b>IRANGE=</b>
	④	<b>WLOW=</b>	<b>WLOW=</b>	<b>IHIGH=</b>
	⑤	<b>WTIMER=</b>	<b>WTIMER=</b>	<b>ILOW=</b>
	⑥	<b>WRTIMER=</b>	<b>WRTIMER=</b>	<b>IMASK=</b>
	⑦	<b>WFTIMER=</b>	<b>WFTIMER=</b>	<b>ITIMER=</b>
	⑧	<b>WFREQ=</b>	<b>WFREQ=</b>	
	⑨	<b>IVOLT=</b>		
	⑩	<b>IRANGE=</b>		
	⑪	<b>IHIGH=</b>		
⑫	<b>ILOW=</b>			
⑬	<b>IMASK=</b>			
⑭	<b>ITIMER=</b>			
	For detail of each command, refer to the respective command descriptions.			
	Transmission example <b>MEM3=MODE=ACWIR,</b> <b>WVOLT=2.50kV,WHIGH=20.00mA,WLOW=OFF,</b> <b>WTIMER=10.0s,WRTIMER=5.0s,WFTIMER=10.0s,WFREQ=60Hz,IVOLT=500V,</b> <b>IRANGE=AUTO,IHIGH=OFF,ILOW=10.00MOHM,IMASK=1.0s,ITIMER=60.0s</b>  			

<b>43) MEM□?</b>	Test mode of memory No. and parameter is read out.			
	Syntax	<b>MEM</b> [Memory No.]? [Memory No.]:1~16		
	Transmission	<b>MEM</b> [Memory No.]?  		
	Response	<b>MEM</b> [Memory No.]= <sup>①</sup> , <sup>②</sup> , <sup>③</sup> , <sup>④</sup> , <sup>⑤</sup> , <sup>⑥</sup> , <sup>⑦</sup> , <sup>⑧</sup> , <sup>⑨</sup> , <sup>⑩</sup> , <sup>⑪</sup> , <sup>⑫</sup> , <sup>⑬</sup> , <sup>⑭</sup>  		
	Test mode			
	ACW-IR or IR-ACW	ACW Individual test	IR Individual test	
①	<b>MODE=</b>	<b>MODE=</b>	<b>MODE=</b>	
②	<b>WVOLT=</b>	<b>WVOLT=</b>	<b>IVOLT=</b>	
③	<b>WHIGH=</b>	<b>WHIGH=</b>	<b>IRANGE=</b>	
④	<b>WLOW=</b>	<b>WLOW=</b>	<b>IHIGH=</b>	
⑤	<b>WTIMER=</b>	<b>WTIMER=</b>	<b>ILOW=</b>	
⑥	<b>WRTIMER=</b>	<b>WRTIMER=</b>	<b>IMASK=</b>	
⑦	<b>WFTIMER=</b>	<b>WFTIMER=</b>	<b>ITIMER=</b>	
⑧	<b>WFREQ=</b>	<b>WFREQ=</b>		
⑨	<b>IVOLT=</b>			
⑩	<b>IRANGE=</b>			
⑪	<b>IHIGH=</b>			
⑫	<b>ILOW=</b>			
⑬	<b>IMASK=</b>			
⑭	<b>ITIMER=</b>			
	For detail of each command, refer to the respective command descriptions.			
	Response example MEM3=MODE=ACWIR, WVOLT=2.50kV, WHIGH=20.00mA, WLOW=OFF, WTIMER=10.0s, WRTIMER=5.0s, WFTIMER=10.0s, WFREQ=60Hz, IVOLT=500V, IRANGE=AUTO, IHIGH=OFF, ILOW=10.00MOHM, IMASK=1.0s, ITIMER=60.0s  			
<b>44) PROGRAM=</b>	Setting of the Program No.			
	Syntax	<b>PROGRAM=</b> [Program No.] [Program No.]: 0~F		
	Transmission	<b>PROGRAM=5</b>   Specify the program to「5」.		
<b>45) PROGRAM?</b>	Program No. is read out.			
	Syntax	<b>PROGRAM?</b>		
	Transmission	<b>PROGRAM?</b>  		
	Response	<b>PROGRAM=8</b>   When Program No.8 is read out.		



47) **PROG□?**

Parameter of Program No. is read out.

Syntax **PROG[Program No.]?**

Transmission **PROG[Program No.]?**

Response **PROG[Program No.]=①,[STEP0], [STEP1], [STEP2], [STEP3], [STEP4], [STEP5], [STEP6], [STEP7], [STEP8], [STEP9], [STEPA], [STEPB], [STEP C], [STEPD], [STEP E], [STEPF]**

Response example

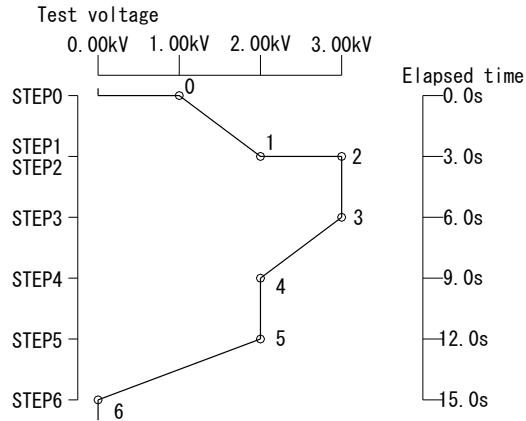

PROG5=WFREQ=60Hz,

STEP=0,WVOLT=1.00kV,WHIGH=10.0mA,WLOW=OFF,WSTIMER=0.1s,

STEP=1,WVOLT=2.00kV,WHIGH=10.0mA,WLOW=OFF,WSTIMER=3.0s,

STEP=2,WVOLT=3.00kV,WHIGH=15.0mA,WLOW=OFF,WSTIMER=0.1s,

STEP=3,WVOLT=3.00kV,WHIGH=15.0mA,WLOW=OFF,WSTIMER=3.0s,

STEP=4,WVOLT=2.00kV,WHIGH=10.0mA,WLOW=OFF,WSTIMER=3.0s,,

STEP=5,WVOLT=2.00kV,WHIGH=10.0mA,WLOW=OFF,WSTIMER=3.0s,,

STEP=6,WVOLT=0.00kV,WHIGH=10.0mA,WLOW=OFF,WSTIMER=3.0s,END,



## 8. Error code and solution tips

Error code	Error contents and countermeasures
ERROR=1	Command format cannot be recognized and the characters are also wrong. Example) STAART、STAT Correct the character string to <b>START</b>
ERROR=2	Parameter is outside the valid range. Example) <b>ITIMER=9999</b> Put it in between <b>0.2~99.9</b>
ERROR=3	Trying to set the parameter in the condition where setting is not possible. Example) When there is Err E-30 or Err E-31 on the front panel, it is a problem of the tester 8505 side and not of the transmission. Refer 「13. Error message」of the Instruction manual of this tester.
TEST	During test or judgment output, the operation other than STOP is performed.
ERROR=6	During <b>REMOTE=OFF</b> , When <b>START</b> command is received. Perform after <b>REMOTE=ON</b> setting.
ERROR=8	Command transmission is performed during test conditions setting. Example) Command transmission is not possible during setting by the front panel operation. Let the setting end and the light on the READY lamp is in turned on condition.
ERROR=9	Command is not appropriate. Example) <ul style="list-style-type: none"> <li>• Even when the previous measurement is the test of PROGRAM operation, <b>DATA?</b> command is received.</li> <li>• When the previous measurement is the test result other than the test of PROGRAM operation, <b>PROGDATA?</b> command is received.</li> <li>• Even when it is not yet measured, <b>DATA?</b> Or <b>PROGDATA?</b> command is received.</li> <li>• Even when FAIL mode is ON, try to cancel NG and PROTECTION with <b>STOP</b> command.</li> </ul>

Regarding protection function operation time (During interlock, error display)

PROTECTION state	Countermeasures
<i>Err HrG</i>	When the capacity of the test specimen is large, discharge is not possible and there is a case where high voltage remains. When <b>DATA?</b> is received at this state, <b>IJUDGE=PROTECT</b> is returned to the host. Besides, if <b>STOP</b> command is received then <b>ERROR=3</b> is returned to the host. Countermeasure Leave it alone for some time and continue the discharge. When the discharge is completed, it is possible that the <b>STOP</b> command or error display in <b>STOP</b> switch is released.
<i>Err LoCP</i>	Even when command is sent in <b>INTERLOCK</b> state, <b>ERROR=3</b> is returned to the host. Countermeasure Release the <b>INTER LOCK</b> and make <b>STOP</b> command or press <b>STOP</b> switch.
<i>Err E-11</i> <i>Err E-21</i>	Cancel the momentary movements. Refer the error contents in 「13. Error message」of the instruction manual of this tester.
<i>Err E-30</i>	It occurs during withstand voltage test, when the internal components are in the overheated state. When <b>DATA?</b> is received at this state, <b>WJUDGE=PROTECT</b> is returned to the host. Besides, if <b>STOP</b> command is received then <b>ERROR=3</b> is returned to the host. Countermeasure There is a possibility of internal components getting overheated during the test for a long time. Wait for a while at the power on state till the heat is dissipated. When the heat dissipation is completed, it is possible that the <b>STOP</b> command or error display in <b>STOP</b> switch is released.





# Tsuruga Electric Corporation

## **Osaka Headquarters**

1-3-23, Minamiumiyoshi, Sumiyoshi-ku, Osaka, Japan 〒558-0041

TEL 81-6 -6692-6700, FAX 81-6 -6609- 8115

E-mail: [cs.info@tsuruga.co.jp](mailto:cs.info@tsuruga.co.jp)

## **Yokohama Office**

1-29-15, Shinyokohama, Kohoku-ku, Yokohama, Kanagawa, Japan 〒222-0033

## **Tokyo Office**

5-25-16, Higashigotanda, Shinagawa-ku, Tokyo, Japan 〒141-0022

## **Nagoya Office**

Sun Park Higashi Betsuin Bld. 2F

5-19, Oicho, Naka-ku, Nagoya, Aichi, Japan 〒460-0015

## **Osaka Plant**

1-3-23, Minami Sumiyoshi, Sumiyoshi-ku, Osaka, Japan 〒558-0041

## **Shiga Plant**

122, Kawasaki-Cho, Nagahama, Shiga, Japan 〒526-0846

[www.tsuruga.co.jp](http://www.tsuruga.co.jp)